



## PRODUCTS AND SOLUTIONS

From the UK's leading materials handling specialist





**Mailbox**  
www.mailboxproducts.co.uk



---

## Over 50 years' experience

across a wide range of market sectors, including  
food manufacturing, warehouse and logistics, retail,  
healthcare and pharmaceutical.

---

**Order online: [www.mailboxproducts.co.uk](http://www.mailboxproducts.co.uk)**



## Products and Solutions

Providing tough, durable, colourful storage solutions that work.

### Contents

6-15	Introduction	52-53	Maximover IBC
16-19	Euro Stacking Boxes 400 x 300mm	54-55	Pallet Tanks
20-22	Euro Stacking Boxes 600 x 400mm	56-57	Foldable Large Container (FLC)
23	Euro Stacking Dolly	58-59	Retail Shopping Baskets
24	Euro Container Trolleys	60-63	Moulded Trucks
25-27	Stacking Boxes 765 x 455mm	64-65	Bottle Trucks
28-29	Bakery Racks	66-67	Mobile and Tabletop Ingredients Bins
30-31	Bread Trays and Dollies	68-69	Scoops, Scrapers and Jugs
32-35	Stacking Boxes 640 x 385mm	70	Shovels, Spades and Snow Pushers
36-37	Retail and Distribution Bale Arm Crates	71	Heavy Duty Grit Bins
38-39	Stack / Nest boxes - RTP Containers	72-73	Pallets
40-41	Attached Lid Boxes 600 x 400mm	74-75	REA Racking - Euro Shelving
42-43	ALCs	76	Wire Racking
44-45	Interstacking Bins	77	Stainless Steel Wire Racking
46	Buckets with Handles	78-79	Swift Racking Flat Pack
47	Tapered Nesting Bins	80	Storage Lockers
48	Rectangular Bins	81-83	Internal Litter Bins
49	Ingredients Trolleys	84	Wheelie Bins
50-51	Rectangular Tanks	85	4-Wheeled Bins
		86-87	Index

### Multi-Use Plastics

All plastics used in the moulding process on site are recyclable. When they finally reach the end of their life, we work closely with customers and our processing partners to have the plastics recycled into new items rather than being sent to landfill.



## Production Site and UK Manufacturing

Virtually all products are made on site in our centrally located UK factory, ensuring we retain control of the entire manufacturing process.

---



## Design-Led Solutions

Our products include multifunctional boxes and trays to streamline processes in the food industry, specialist cabinets to help hospitals store vital equipment safely and efficiently, and IBCs for a wide variety of bulk storage needs.

Our ranges are constantly evolving in response to technological advances, changing customer needs and global markets. If required, we can even work with customers to develop bespoke solutions.

---





## Concept through to Production

We work closely with customers, from discussing and developing initial concepts, technical designing and prototyping, through to commissioning tooling and manufacturing the final product.

---



## Quality Control

We represent the absolute best of the UK manufacturing industry, producing highly effective storage products conceived and constructed by skilled and committed staff working out of our impressive head office.

---



## Product Personalisation

We offer a wide range of product personalisation options for a truly bespoke experience – your graphics, your text, our products.

---







## Accreditations and Associations

We are recognised by the UK's leading associations and accrediting agencies.



## Reuse, Return, Recycle

We are committed to making all our processes as environmentally friendly as possible, reducing waste and recycling.

We sincerely care about how what we do impacts on our planet and are proud to be fully accredited to the ISO 1400:2015 environmental manufacturing system.



## Working With People

Over the phone or in person, Mailbox Products is always there to support your business.

**Tel: +44 (0)161 330 5577**

**Email: [sales@mailboxproducts.co.uk](mailto:sales@mailboxproducts.co.uk)**

Mailbox: Stamford Products Limited,  
Bayley Street, Stalybridge, Cheshire. SK15 1QQ

**[www.mailboxproducts.co.uk](http://www.mailboxproducts.co.uk)**

## Improving Efficiency

We work closely with customers to develop systems that improve efficiency and streamline procedures.

This may be through refinements to an existing system or development of an entirely new one. A streamlined process means fewer errors and delays.

**Mailbox**  
[www.mailboxproducts.co.uk](http://www.mailboxproducts.co.uk)





OX  
CO.UK





## Trade Shows and Exhibitions

We are always keen to share our innovative materials handling solutions with a wide national and international market.

We regularly participate in trade shows and exhibitions, attracting many visitors to our colourful stands.



## Food-Approved Materials

In the food industry, sorting and segregation of product is extremely important, but there are no national guidelines when it comes to colour choices – a colour that denotes fish in one company could mean dairy in another.

With our containers, you can develop your own colour-coding system or complement an existing one. With virtually all our products available from stock, this can be done quickly and efficiently to meet the needs of a fast-moving market.

- Made from food-grade materials
- Easy to clean
- Robust and durable
- Personalisation options available



# Euro Stacking Boxes

400 x 300mm

Mailbox Products 400 x 300mm Euro size plastic stacking containers are space-saving by design and are manufactured to fit Euro and Industrial pallet sizes. They are available in solid and perforated options for products that require ventilation. They have a strong profile handle for easy lifting and come in a wide variety of colours to integrate with any colour-coding or branding strategy.

- Made from food-grade materials
- Easy to clean
- Robust and durable
- Positive stacking for safety
- Up to 10 colour options
- Personalisation options available

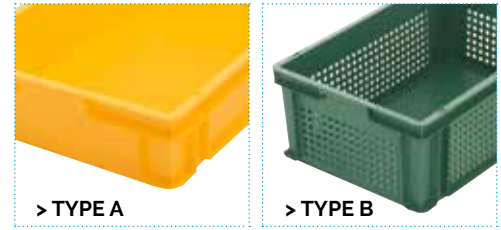

- A: Solid sides and base with hand grips
- B: 10 x 10mm perforated side, solid base panels with hand grips, except M205B which has hand holes

400 (L) x 300 (W) x 120 (H) mm  
11 Litre Stacking Box - Solid Sides & Base  
With Short Side Hand Grips



Code	M203A
Dims Int	352 (L) x 252 (W) x 105 (H) mm
Capacity	11 Litres
Weight (kg)	0.8
Material	PP
Drop-on Lid	M214
Hinged Lid	M214A

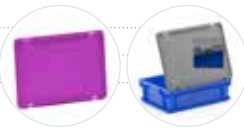

Food-grade material

Robust & durable

Personalisation area



10 colour options

Hand grip

Strengthening ribs

Ideal for food production lines







400 (L) x 300 (W) x 120 (H) mm  
11 Litre Stacking Box - Perforated Sides  
With Solid Base & Short Side Hand Grips

Colour: 

<b>Code</b>	<b>M203B</b>
<b>Dims Int</b>	352 (L) x 252 (W) x 105 (H) mm
<b>Capacity</b>	11 Litres
<b>Weight (kg)</b>	0.8
<b>Material</b>	PP
<b>Drop-on Lid</b>	M214
<b>Hinged Lid</b>	M214A

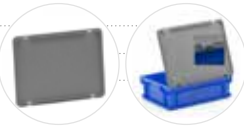

400 (L) x 300 (W) x 170 (H) mm  
15.5 Litre Stacking Box - Solid Sides & Base  
With Hand Grip

Colour: 

<b>Code</b>	<b>M207A</b>
<b>Dims Int</b>	350 (L) x 250 (W) x 155 (H) mm
<b>Capacity</b>	15.5 Litres
<b>Weight (kg)</b>	0.9
<b>Material</b>	PP
<b>Drop-on Lid</b>	M214
<b>Hinged Lid</b>	M214A

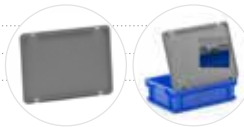

400 (L) x 300 (W) x 170 (H) mm  
15.5 Litre Stacking Box - 10 x 10mm  
Perforated Sides & Solid Base with Hand Grips

Colour: 

<b>Code</b>	<b>M207B</b>
<b>Dims Int</b>	350 (L) x 250 (W) x 155 (H) mm
<b>Capacity</b>	15.5 Litres
<b>Weight (kg)</b>	0.8
<b>Material</b>	PP
<b>Drop-on Lid</b>	M214
<b>Hinged Lid</b>	M214A

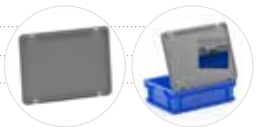

400 (L) x 300 (W) x 220 (H) mm  
19.8 Litre Stacking Box - Solid Sides & Base  
With Hand Grips

Colour: 

<b>Code</b>	<b>M204A</b>
<b>Dims Int</b>	345 (L) x 245 (W) x 205 (H) mm
<b>Capacity</b>	19.8 Litres
<b>Weight (kg)</b>	1.01
<b>Material</b>	PP
<b>Drop-on Lid</b>	M214
<b>Hinged Lid</b>	M214A

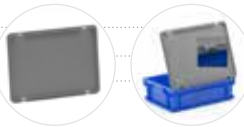

400 (L) x 300 (W) x 220 (H) mm  
19.8 Litre Stacking Box - Perforated Sides &  
Solid Base With Hand Grips

Colour: 

<b>Code</b>	<b>M204B</b>
<b>Dims Int</b>	345 (L) x 245 (W) x 205 (H) mm
<b>Capacity</b>	19.8 Litres
<b>Weight (kg)</b>	1.00
<b>Material</b>	PP
<b>Drop-on Lid</b>	M214
<b>Hinged Lid</b>	M214A



400 (L) x 300 (W) x 325 (H) mm  
30.2 Litre Stacking Box - Solid Sides & Base  
With Hand Grips

Colour: 

<b>Code</b>	<b>M205A</b>
<b>Dims Int</b>	350 (L) x 250 (W) x 310 (H) mm
<b>Capacity</b>	30.2 Litres
<b>Weight (kg)</b>	1.5
<b>Material</b>	PP
<b>Drop-on Lid</b>	M214
<b>Hinged Lid</b>	M214A

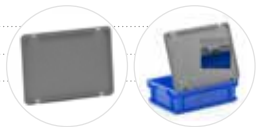



**Mailbox**  
www.mailboxproducts.co.uk

Order online: [www.mailboxproducts.co.uk](http://www.mailboxproducts.co.uk) | Call: 0161 330 5577 | Email: [sales@mailboxproducts.co.uk](mailto:sales@mailboxproducts.co.uk)



## Euro Stacking Boxes 400 x 300mm

Euro size stacking containers are extremely versatile and suitable for warehouse storage as well as a multitude of other applications. If used in circulation and distribution to customers and suppliers, they provide an easy alternative to containers that require repackaging, minimising waste.

- Made from food-grade materials
- Easy to clean
- Robust and durable



400 (L) x 300 (W) x 325 (H) mm  
30.2 Litre Stacking Box - 10 x 10mm  
Perforated Sides and Solid Base with  
Handholes

Colour: 

Code	M205B
Dims Int	350 (L) x 250 (W) x 310 (H) mm
Capacity	30.2 Litres
Weight (kg)	1.4
Material	PP
Drop-on Lid	M214
Hinged Lid	M214A

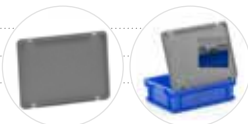

400 (L) x 300 (W) x 10 (H) mm  
Drop on Lid for M203 M204 M205 M207

Colour: 

Code	M214
Dims Ext	400 (L) x 300 (W) x 10 (H) mm
Weight (kg)	0.35
Material	PP



400 (L) x 300 (W) x 10 (H) mm  
Hinged Lid for M203 M204 M205 M207

Colour: 

Code	M214A
Dims Ext	400 (L) x 300 (W) x 10 (H) mm
Weight (kg)	0.35
Material	PP

# Euro Stacking Boxes

600 x 400mm

Mailbox Products 600 x 400mm Euro size plastic stacking containers are the most popular size option. Optimum capacity by design, these containers are manufactured to fit Euro and Industrial pallet sizes and are an excellent way to standardise and streamline transport and storage logistics. They are available in solid and perforated options and come in a wide range of colours and heights to integrate with any colour-coding or branding strategy.

- Made from food-grade materials
- Available in a wide variety of colours
- Easy to clean
- Robust and durable
- Profile handle for easy lifting
- Personalisation options available

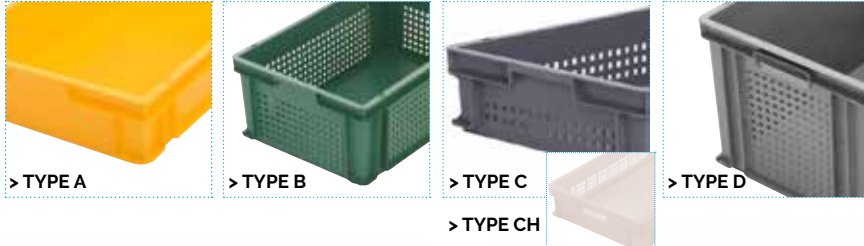

- A: Solid sides and base
- B: Perforated sides and solid base
- C: Perforated sides and base
- CH: Perforated sides and base with hand holes
- D: Perforated short sides and solid base



600 (L) x 400 (W) x 120 (H) mm  
23.7 Litre Euro Stacking Box - Solid Sides & Base with Short Side Hand Grips



Code	M200A
Dims Int	552 (L) x 352 (W) x 105 (H) mm
Capacity	23.7 Litres
Weight (kg)	1.4
Material	PP
Drop on lid	M213
Hinged lid	M213A

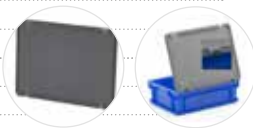

600 (L) x 400 (W) x 120 (H) mm  
23.7 Litre Euro Stacking Box - Perforated Sides with Solid Base & Short Side Hand Grips



Code	M200B
Dims Int	552 (L) x 352 (W) x 105 (H) mm
Capacity	23.7 Litres
Weight (kg)	1.3
Material	PP
Drop on lid	M213
Hinged lid	M213A

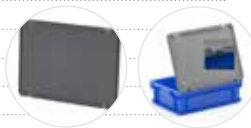

600 (L) x 400 (W) x 120 (H) mm  
23.7 Litre Euro Stacking Box - Perforated Sides & Base With Hand Holes in Short Sides



Code	M200CH
Dims Int	552 (L) x 352 (W) x 105 (H) mm
Capacity	23.7 Litres
Weight (kg)	1.2
Material	PP
Drop on lid	M213
Hinged lid	M213A

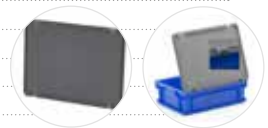

600 (L) x 400 (W) x 170 (H) mm  
33 Litre Euro Stacking Box - Solid Sides & Base with Short Side Hand Grips



Code	M208A
Dims Int	554 (L) x 354 (W) x 167 (H) mm
Capacity	33 Litres
Weight (kg)	1.64
Material	PP
Drop on lid	M213
Hinged lid	M213A

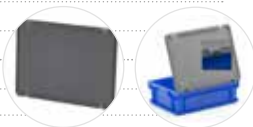

600 (L) x 400 (W) x 170 (H) mm  
33 Litre Euro Stacking Box - Perforated Sides with Solid Base & Short Side Hand Grips



Code	M208B
Dims Int	554 (L) x 354 (W) x 167 (H) mm
Capacity	33 Litres
Weight (kg)	1.54
Material	PP
Drop on lid	M213
Hinged lid	M213A

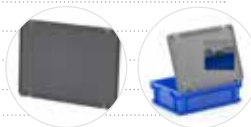

600 (L) x 400 (W) x 220 (H) mm  
 43.8 Litre Euro Stacking Box - Solid Sides & Base with Hand Grips



Code **M201A**  
 Dims Int 545 (L) x 345 (W) x 205 (H) mm  
 Capacity 43.8 Litres  
 Weight (kg) 1.9  
 Material PP  
 Drop-on Lid M213  
 Hinged Lid M213A

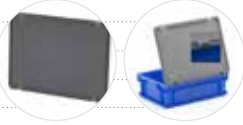

Food-grade material

Strengthening ribs



Personalisation area



9 colour options

Hand grip

Secure stacking



# Euro Stacking Boxes

600 x 400mm

Euro size stacking containers are extremely versatile and suitable for warehouse storage as well as a multitude of other applications. If used in circulation and distribution to customers and suppliers, they provide a more environmentally-friendly alternative to single trip packaging.

- Made from food-grade materials
- Easy to clean
- Robust and durable
- Stack for easy storage



**600 (L) x 400 (W) x 220 (H) mm**  
**43.8 Litre Euro Stacking Box - Perforated Sides with Solid Base & Short Side Hand Grips**

Colour:

<b>Code</b>	<b>M201B</b>
<b>Dims Int</b>	545 (L) x 345 (W) x 205 (H) mm
<b>Capacity</b>	43.8 Litres
<b>Weight (kg)</b>	1.7
<b>Material</b>	PP
<b>Drop-on Lid</b>	M213
<b>Hinged Lid</b>	M213A

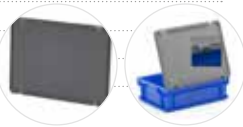

**600 (L) x 400 (W) x 235 (H) mm**  
**45 Litre Euro Stacking Box - Solid Sides & Base with Hand Grips**

Colour:

<b>Code</b>	<b>M212A</b>
<b>Dims Int</b>	550 (L) x 350 (W) x 220 (H) mm
<b>Capacity</b>	45 Litres
<b>Weight (kg)</b>	2.2
<b>Material</b>	PP
<b>Drop-on Lid</b>	M213

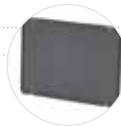

**600 (L) x 400 (W) x 325 (H) mm**  
**65 litre Euro Stacking Box - Solid Sides & Base With Short Side Hand Grips**

Colour:

<b>Code</b>	<b>M202A</b>
<b>Dims Int</b>	550 (L) x 350 (W) x 310 (H) mm
<b>Capacity</b>	65 Litres
<b>Weight (kg)</b>	2.5
<b>Material</b>	PP
<b>Drop-on Lid</b>	M213
<b>Hinged Lid</b>	M213A

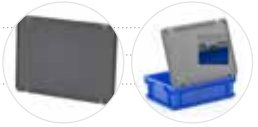

**600 (L) x 400 (W) x 325 (H) mm**  
**65 Litre Euro Stacking Box - 10 x 10mm Perforated Short Sides With Hand Holes, Solid Long Walls & Solid Base.**

Colour:

<b>Code</b>	<b>M202D</b>
<b>Dims Int</b>	550 (L) x 350 (W) x 310 (H) mm
<b>Capacity</b>	65 Litres
<b>Weight (kg)</b>	2.2
<b>Material</b>	PP
<b>Drop-on Lid</b>	M213
<b>Hinged Lid</b>	M213A



**600 (L) x 400 (W) x 425 (H) mm**  
**84.5 Litre Euro Stacking Box - Solid Sides & Base With Hand Holes On All 4 Walls.**

Colour:

<b>Code</b>	<b>M209A</b>
<b>Dims Int</b>	550 (L) x 350 (W) x 410 (H) mm
<b>Capacity</b>	84.5 Litres
<b>Weight (kg)</b>	3.0
<b>Material</b>	PP
<b>Drop-on Lid</b>	M213
<b>Hinged Lid</b>	M213A



## Personalisation options available



# Euro Stacking Dolly

Robust and easy to clean

Mailbox Products plastic wheeled dollies are a secure and effective way to move items with ease in warehouses, shops and offices. Because minimal effort is required, they are much safer for users than lifting. They also save the time wasted on repeat journeys as many plastic containers, boxes and trays can be stacked or nested on the dolly, meaning fewer trips to and from locations.

- Heavy-duty
- Euro dollies
- Easy to manoeuvre
- Durable
- Food-approved plastic
- Hygienic and compact
- Personalisation options available



650 (L) x 450 (W) x 190 (H) mm  
Euro and Tower Range Dolly



Code	R1173
Dims Int	605 (L) x 407 (W) x 25 (H) mm
Weight (kg)	4.25
Material	MDPE

Hygienic and easily cleaned

Smooth surfaces

Stability by design



10 colour options



100mm nylon castors

All swivel castors

Food-approved use

Capable of carrying a weight load of up to 250kg



# Euro Container Trolleys

High density mobile storage and distribution

Mailbox Products Euro container trolleys come in single and double options. They are compatible with Euro sized containers. Manufactured from mild steel and epoxy-coated in silver for a hard-wearing and easy-to-clean finish, with a wide choice of coloured containers, they are ideal for use in busy picking and sorting environments

- Fully welded construction
- Durable container trolley
- Easy to manoeuvre
- Offering multiple container colour choices



**456 (L) x 614 (W) x 1500 (H) mm**  
Single Euro Trolley for use with  
5 x M201 Containers 600 x 400 x 220mm

<b>Code</b>	<b>H201-5</b>
<b>Dims Ext</b>	456 (L) x 614 (W) x 1500 (H) mm
<b>Castors</b>	100mm
<b>Material</b>	Mild Steel
<b>Coated</b>	Silver



**456 (L) x 614 (W) x 1500 (H) mm**  
Single Euro Trolley for use with  
8 x M200 Containers 600 x 400 x 120mm

<b>Code</b>	<b>H200-8</b>
<b>Dims Ext</b>	456 (L) x 614 (W) x 1500 (H) mm
<b>Castors</b>	100mm
<b>Material</b>	Mild Steel
<b>Coated</b>	Silver



**887 (L) x 614 (W) x 1500 (H) mm**  
Double Euro Trolley for use with  
10 x M201 Containers 600 x 400 x 220mm

<b>Code</b>	<b>H201-10</b>
<b>Dims Ext</b>	887 (L) x 614 (W) x 1500 (H) mm
<b>Castors</b>	100mm
<b>Material</b>	Mild Steel
<b>Coated</b>	Silver



**M200 containers**

**Robust and easy to clean**

**887 (L) x 614 (W) x 1500 (H) mm**  
Double Euro Trolley for use with  
16 x M200 Containers 600 x 400 x 120 mm

<b>Code</b>	<b>H200-16</b>
<b>Dims Ext</b>	887 (L) x 614 (W) x 1500 (H) mm
<b>Castors</b>	100mm
<b>Material</b>	Mild Steel
<b>Coated</b>	Silver





**Wide choice of coloured containers**



**Easy to manoeuvre**

**Heavy duty runners**

**Epoxy-coated mild steel**

**100mm Non marking rubber castors**





## Stacking Boxes 765 x 455mm

Mailbox Products 765 x 455mm stacking boxes have a multitude of applications and are an ideal alternative to corrugated packaging for moving and storing goods. Durable and easy-to-clean, they are suitable for use across many sectors from education to car manufacture and stack for easy, space-saving storage. Perforated options and food grade virgin polypropylene construction makes them ideal for the food industry or for any products that need ventilated storage, and they are often found in bakery and confectionery environments.

- **Variety of capacities and colours**
- **Available in food grade virgin polypropylene or high density polyethylene**
- **Robust and durable**
- **Stack for easy storage**
- **Up to 8 colour options on trays, 10 colour options on dollies**
- **Personalisation options available**



**765 (L) x 455 (W) x 90 (H) mm**  
**20 Litre Stacking Box - with Solid Sides,**  
**18 x 18mm Perforated Base**

Colour: 

<b>Code</b>	<b>M111A</b>
<b>Dims Int</b>	735 (L) x 425 (W) x 80 (H) mm
<b>Capacity</b>	20 Litres
<b>Weight (kg)</b>	1.7
<b>Material</b>	HDPE
<b>Drop-on Lid</b>	R1142



**765 (L) x 455 (W) x 90 (H) mm**  
**20 Litre Stacking Box - with Solid Sides**  
**& Base**

Colour: 

<b>Code</b>	<b>M111B</b>
<b>Dims Int</b>	735 (L) x 425 (W) x 80 (H) mm
<b>Capacity</b>	20 Litres
<b>Weight (kg)</b>	1.8
<b>Material</b>	PP
<b>Drop-on Lid</b>	R1142



**765 (L) x 455 (W) x 90 (H) mm**  
**20 Litre Stacking Box - with Slots in Long**  
**Side and 4 x 4mm Perforated Base**

Colour: 

<b>Code</b>	<b>M111C</b>
<b>Dims Int</b>	735 (L) x 425 (W) x 80 (H) mm
<b>Capacity</b>	20 Litres
<b>Weight (kg)</b>	2.1
<b>Material</b>	HDPE
<b>Drop-on Lid</b>	R1142



# Stacking Boxes

765 x 455mm

**Mailbox**  
www.mailboxproducts.co.uk



**765 (L) x 455 (W) x 90 (H) mm**  
**20 Litre Stacking Box - with 18mm x 18mm Mesh Sides & Base**

**765 (L) x 455 (W) x 90 (H) mm**  
**20 Litre Stacking Box - 18mm x 18mm Mesh Sides & Solid Base**

**805 (L) x 505 (W) x 175 (H) mm**  
**Compact Stacking Dolly for M111 M211 M311**

Colour:

Colour:

Colour:

<b>Code</b>	<b>M111D</b>
<b>Dims Int</b>	735 (L) x 425 (W) x 80 (H) mm
<b>Capacity</b>	20 Litres
<b>Weight (kg)</b>	1.7
<b>Material</b>	HDPE
<b>Drop-on Lid</b>	R1142



<b>Code</b>	<b>M111E</b>
<b>Dims Int</b>	735 (L) x 425 (W) x 80 (H) mm
<b>Capacity</b>	20 Litres
<b>Weight (kg)</b>	1.8
<b>Material</b>	PP
<b>Drop-on Lid</b>	R1142



<b>Code</b>	<b>R1210</b>
<b>Dims Int</b>	805 (L) x 505 (W) x 175 (H) mm
<b>Weight (kg)</b>	5.6
<b>Material</b>	MDPE
<b>All Castors</b>	75mm nylon swivel



Ideal for bakery food production and display



We offer a wide range of product personalisation options for a truly bespoke experience – your graphics, your text, our products.

Used with M111 M211 and M311

Drop-on lid



Confectionery trays

765 (L) x 455 (W) x 10 (H) mm  
Drop on lid For M111 M211 & M311

Colour:

**Code** R1142  
**Dims Ext** 765 (L) x 455 (W) x 10 (H) mm  
**Weight (kg)** 1.2  
**Material** HDPE

Protects contents

Strengthening ribs



765 (L) x 455 (W) x 125 (H) mm  
30 Litre Stacking Box - with Solid Sides & Base

Colour:

**Code** M211B  
**Dims Int** 735 (L) x 425 (W) x 110 (H) mm  
**Capacity** 30 Litres  
**Weight (kg)** 2.1  
**Material** PP  
**Drop-on Lid** R1142



765 (L) x 455 (W) x 125 (H) mm  
30 Litre Stacking Box - with Solid Sides, Solid Base & Hand Holes

Colour:

**Code** M211BH  
**Dims Int** 735 (L) x 425 (W) x 110 (H) mm  
**Capacity** 30 Litres  
**Weight (kg)** 2.1  
**Material** PP  
**Drop-on Lid** R1142



765 (L) x 455 (W) x 125 (H) mm  
30 Litre Stacking Box - with 18mm x 18mm Mesh Sides, Mesh Base & Hand Holes

Colour:

**Code** M211DH  
**Dims Int** 735 (L) x 425 (W) x 110 (H) mm  
**Capacity** 30 Litres  
**Weight (kg)** 2.0  
**Material** HDPE  
**Drop-on Lid** R1142



765 (L) x 455 (W) x 175 (H) mm  
50 Litre Stacking Box - with Solid Sides & Base

Colour:

**Code** M311B  
**Dims Int** 735 (L) x 425 (W) x 160 (H) mm  
**Capacity** 50 Litres  
**Weight (kg)** 2.5  
**Material** PP  
**Drop-on Lid** R1142



765 (L) x 455 (W) x 175 (H) mm  
50 Litre Stacking Box - with Solid Sides, Solid Base & Hand Holes

Colour:

**Code** M311BH  
**Dims Int** 735 (L) x 425 (W) x 160 (H) mm  
**Capacity** 50 Litres  
**Weight (kg)** 2.5  
**Material** PP



765 (L) x 455 (W) x 175 (H) mm  
50 Litre Stacking Box - with 18mm x 18mm Mesh Sides, Mesh Base & Hand Holes

Colour:

**Code** M311DH  
**Dims Int** 735 (L) x 425 (W) x 160 (H) mm  
**Capacity** 50 Litres  
**Weight (kg)** 2.6  
**Material** HDPE



Also see:

- Page 25-26 M111 container trays
- Page 48 - 49 Rectangular bins and trolleys
- Page 66 - 67 Ingredients trolleys and Bins
- Stainless steel worktops available on request



## Bakery Racks

M111 container frames - See page 25-26 for containers

Bakery racks are an essential part of any commercial bakery. They are used to store confectionery trays and bakery trays safely off the floor. The open design allows products to cool without going soggy. They are also suitable for other food contact environments.

- Mild or stainless steel options
- Fully welded construction
- Easy-to-maneuvre bakery trolleys
- Easy-clean catering storage

Code	L	W	H	Capacity*	Weight	Material
H111SS	860	590	1820	16 x M111 containers	44.0 Kgs	Stainless steel
H111	860	590	1820	16 x M111 containers	44.0 Kgs	Epoxy coated mild steel
H1118SS	820	520	1060	8 x M111 containers	25.0 Kgs	Stainless steel
H1118	820	520	1060	8 x M111 containers	25.0 Kgs	Epoxy coated mild steel

\*Containers not included



# Bread Trays

## Distribution and display

Bread trays have drop front openings for easy access to the contents in the tray. Made from food-grade polypropylene (PP), they can be stacked on top of one another as well as having nesting features making them compact for storage. They are hard wearing and easy to clean.

- Made from food-grade materials
- Easy to clean
- Robust and durable
- Stack for easy storage



**665 (L) x 555 (W) x 185 (H) mm**  
**10 Loaf Bread Tray**  
**Open Front for Easy Access**

Colour: 

<b>Code</b>	<b>D10</b>
<b>Dims Int</b>	610 (L) x 520 (W) x 170 (H) mm
<b>Capacity</b>	10 loaf
<b>Weight (kg)</b>	1.75
<b>Material</b>	PP



**560 (L) x 745 (W) x 165 (H) mm**  
**12 Loaf Bread Tray**  
**Open Front for Easy Access**

Colour: 

<b>Code</b>	<b>D12</b>
<b>Dims Int</b>	505 (L) x 680 (W) x 140 (H) mm
<b>Capacity</b>	12 loaf
<b>Weight (kg)</b>	2.0
<b>Material</b>	PP



# Bread Tray Dollies

Move trays easily

Dollies are a secure and effective way to move items with ease. They also save the time wasted on repeat journeys as many trays can be stacked or nested on the dolly, meaning fewer trips to and from locations.



**680 (L) x 535 (W) x 140 (H) mm**  
**Dolly for use with 10 Loaf Bread Tray**

<b>Code</b>	<b>H1004</b>
<b>Used with</b>	D10 bread tray
<b>Weight Load (kg)</b>	250
<b>Weight (kg)</b>	4.25
<b>Material</b>	Mild steel



**543 (L) x 663 (W) x 150 (H) mm**  
**Dolly for use with 10 Loaf Bread Tray**

<b>Code</b>	<b>D1004</b>
<b>Used with</b>	D10 bread tray
<b>Weight Load (kg)</b>	250
<b>Weight (kg)</b>	4.2
<b>Material</b>	PP



**750 (L) x 560 (W) x 140 (H) mm**  
**Dolly for use with 12 Loaf Bread Tray**

<b>Code</b>	<b>H12</b>
<b>Used with</b>	D12 bread tray
<b>Weight Load (kg)</b>	250
<b>Weight (kg)</b>	4.25
<b>Material</b>	Mild steel





- A: Solid sides and 3 row perforated base with hand holes
- B: Solid sides and base
- C: Solid sides and base with hand holes in each sort side
- D: Perforated side and base panels, solid ends with hand holes in each short side





# Stacking Boxes

640 x 385mm

Mailbox Products 640 x 385mm stacking boxes are especially suitable for applications where hygiene & strength is important. Designed with large radius corners making them easy to clean, they are also manufactured to withstand demanding environments.

Perforated options and food grade virgin material construction makes them ideal for the food industry or for any products that need ventilated storage.

They are widely used in food production areas, especially meat processing and fish processing.

- Available in a variety of capacities and colours
- Made of food-grade virgin material
- Various design options
- Easy to clean
- Robust and durable
- Space-saving
- Stackable for easy storage
- Personalisation options available

## 640 (L) x 385 (W) x 150 (H) mm 28.5 Litre Stacking Box - Solid Sides, 3 Row Perforated Base & Hand Hole

Colour: 

<b>Code</b>	<b>M104A</b>
<b>Dims Int</b>	600 (L) x 340 (W) x 145 (H) mm
<b>Capacity</b>	28.5 Litres
<b>Weight (kg)</b>	1.9
<b>Material</b>	HDPE
<b>Drop-on Lid</b>	E8104
<b>Dolly</b>	E1104



Food-grade virgin material

Heavy-duty stacking boxes

Personalisation area

Perforated Base on M104A and M104D

Hand hole

Strengthening ribs



## 640 (L) x 385 (W) x 150 (H) mm 28.5 Litre Stacking Box - with Solid Sides & Base

Colour:      

<b>Code</b>	<b>M104B</b>
<b>Dims Int</b>	600 (L) x 340 (W) x 145 (H) mm
<b>Capacity</b>	28.5 Litres
<b>Weight (kg)</b>	2.0
<b>Material</b>	HDPE
<b>Drop-on Lid</b>	E8104
<b>Dolly</b>	E1104



## 640 (L) x 385 (W) x 150 (H) mm 28.5 Litre Stacking Box - With Solid Sides, Solid Base & Hand Holes

Colour:      

<b>Code</b>	<b>M104C</b>
<b>Dims Int</b>	600 (L) x 340 (W) x 145 (H) mm
<b>Capacity</b>	28.5 Litres
<b>Weight (kg)</b>	2.0
<b>Material</b>	HDPE
<b>Drop-on Lid</b>	E8104
<b>Dolly</b>	E1104

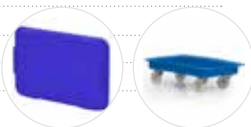

## 640 (L) x 385 (W) x 150 (H) mm 28.5 Litre Stacking Box - With Perforated Sides, 3 Row Perforated Base, Solid Ends & Hand Holes

Colour: 

<b>Code</b>	<b>M104D</b>
<b>Dims Int</b>	600 (L) x 340 (W) x 145 (H) mm
<b>Capacity</b>	28.5 Litres
<b>Weight (kg)</b>	1.9
<b>Material</b>	HDPE
<b>Drop-on Lid</b>	E8104
<b>Dolly</b>	E1104





**640 (L) x 385 (W) x 205 (H) mm**  
**38 Litre Stacking Box - Solid Sides & Base**  
**With Short Side Hand Grips**

Colour:

<b>Code</b>	<b>M118B</b>
<b>Dims Int</b>	600 (L) x 340 (W) x 200 (H) mm
<b>Capacity</b>	38 Litres
<b>Weight (kg)</b>	2.3
<b>Material</b>	HDPE
<b>Drop-on Lid</b>	E8104
<b>Dolly</b>	E1104

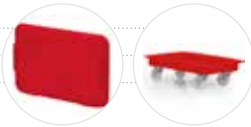

**640 (L) x 385 (W) x 205 (H) mm**  
**38 Litre Stacking Box - with Solid Sides,**  
**Solid Base & Hand Holes**

Colour:

<b>Code</b>	<b>M118C</b>
<b>Dims Int</b>	600 (L) x 340 (W) x 200 (H) mm
<b>Capacity</b>	38 Litres
<b>Weight (kg)</b>	2.3
<b>Material</b>	HDPE
<b>Drop-on Lid</b>	E8104
<b>Dolly</b>	E1104



**640 (L) x 385 (W) x 205 (H) mm**  
**38 litre Stacking Box - with Slots In The Top**  
**Rim, Solid Base & Hand Grips**

Colour:

<b>Code</b>	<b>M118D</b>
<b>Dims Int</b>	600 (L) x 340 (W) x 200 (H) mm
<b>Capacity</b>	38 Litres
<b>Weight (kg)</b>	2.3
<b>Material</b>	HDPE
<b>Drop-on Lid</b>	E8104
<b>Dolly</b>	E1104



**Personalisation options available**



**640 (L) x 385 (W) x 10 (H) mm**  
**Drop on Stacking Lid for M104 M118**

Colour:

<b>Code</b>	<b>E8104</b>
<b>Dims Ext</b>	640 (L) x 385 (W) x 10 (H) mm
<b>Weight (kg)</b>	0.8
<b>Material</b>	LDPE



**650 (L) x 395 (W) x 130 (H) mm**  
**Dolly for use with M104 & M118 Stacking**  
**Boxes & Trays**

Colour:

<b>Code</b>	<b>E1104</b>
<b>Dims Ext</b>	650 (L) x 395 (W) x 130 (H) mm
<b>Weight (kg)</b>	4.6
<b>Material</b>	MDPE
<b>Castors</b>	100mm nylon



We offer a wide range of product personalisation options for a truly bespoke experience – your graphics, your text, our products.







## Retail and Distribution Bale Arm Crates

400 x 300 and 600 x 400

With up to 75% nesting capabilities, Ultraneat gives you the ultimate RTP logistics stack nest crate system. These containers have swing bars that allow positive stacking when in use and then fold away to allow the containers to nest when empty, optimising valuable distribution and storage space.

They are manufactured in high grade virgin materials, making them suitable for food contact and also temperature controlled environments. The perforated design of each container has specifically been chosen to improve airflow while maintaining the tare weights that the market demands.



400 (L) x 300 (W) x 180 (H) mm  
15 Litre Retail and Distribution Bale Arm Crates



<b>Code</b>	<b>M740</b>
<b>Dims Int</b>	364 (L) x 262 (W) x 147 (H) mm
<b>Capacity</b>	15 Litres
<b>Weight (kg)</b>	0.966
<b>Material</b>	PP
<b>Rod Material</b>	Glass filled nylon



600 (L) x 400 (W) x 167 (H) mm  
28 Litre Retail and Distribution Bale Arm Crates



<b>Code</b>	<b>M767</b>
<b>Dims Int</b>	545 (L) x 348 (W) x 143 (H) mm
<b>Capacity</b>	28 Litres
<b>Weight (kg)</b>	1.47
<b>Material</b>	PP
<b>Rod Material</b>	Glass filled nylon



Strong swing bars



Short wall hand holes

Label holder

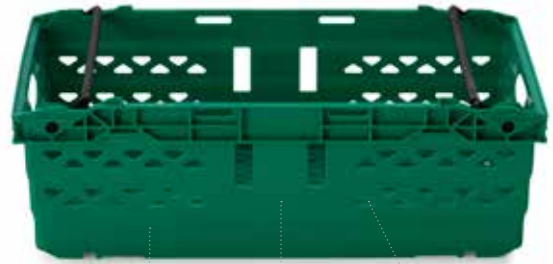

Barcode recess

Ventilated walls

Personalisation area

600 (L) x 400 (W) x 197 (H) mm  
35 Litre Retail and Distribution Bale Arm Crates



Code	M725
Dims Int	545 (L) x 347 (W) x 173 (H) mm
Capacity	35 Litres
Weight (kg)	1.61
Material	PP
Rod Material	Glass filled nylon

10 colour options



Logo / embossed plate area



605 (L) x 400 (W) x 190 (H) mm  
Euro Stacking Dolly - Heavy Duty Stacking Dolly  
Crate not included



Code	R1174
Dims Int	565 (L) x 370 (W) x 35 (H) mm
Weight (kg)	4.2
Material	MDPE
Castors	100mm swivel nylon

## Go Green

New containers from recycled material

Not suitable for direct food contact applications



Recycled 15 Litre Retail and Distribution  
Bale Arm Crates

Colour:

Code	M740R - Recycled
Dims Int	364 (L) x 262 (W) x 147 (H) mm
Capacity	15 Litres
Weight (kg)	0.966
Material	Recycled PP



Recycled 35 Litre Retail and Distribution  
Bale Arm Crates

Colour:

Code	M725R - Recycled
Dims Int	545 (L) x 347 (W) x 173 (H) mm
Capacity	35 Litres
Weight (kg)	1.61
Material	Recycled PP

# Stack / Nest Boxes

## RTP containers

Mailbox Products stack / nest containers are designed to stack when they are in use and nest inside each other when they are empty. This space-saving feature means this range is ideal for use as Return Trip Packaging as when nested on the return trip they can nest up to 50% of their total volume.

- Ideal for use on conveyor systems
- Stack / Nest containers with rods
- Stack / Nest using lids
- Strong bale arms
- Personalisation options available



**590 (L) x 390 (W) x 250 (H) mm  
49.5 Litre Euro Size Heavy Duty Bale Arm  
Stack / Nest Box**

Colour:

Code	<b>M712SN</b>
Dims Int	560 (L) x 330 (W) x 235 (H) mm
Capacity	49.5 Litres
Weight (kg)	2.5
Material	PP
Bale Arm	
Material	Glass filled nylon



**590 (L) x 390 (W) x 250 (H) mm  
49.5 Litre Euro Size Heavy Duty Bale Arm  
Stack / Nest Box – Slotted Sides and Solid  
Base with Drainage Holes**

Colour:

Code	<b>M716SN</b>
Dims Int	530 (L) x 330 (W) x 235 (H) mm
Capacity	49.5 Litres
Weight (kg)	2.3
Material	PP
Bale Arm	
Material	Glass filled nylon



**590 (L) x 390 (W) x 350 (H) mm  
68 Litre Euro Size Heavy Duty Bale Arm  
Stack / Nest Box**

Colour:

Code	<b>M713SN</b>
Dims Int	503 (L) x 310 (W) x 345 (H) mm
Capacity	68 Litres
Weight (kg)	2.7
Material	PP
Bale Arm	
Material	Glass filled nylon



**600 (L) x 400 (W) x 10 (H) mm  
Drop on lid for M712 & M713**

Colour:

Code	<b>M715</b>
Dims Ext	600 (L) x 400 (W) x 10 (H) mm
Weight (kg)	0.9
Material	PP



**800 (L) x 600 (W)  
Double Euro Stacking Dolly -  
Heavy Duty Double Stacking Dolly**

Colour:

Code	<b>R1208</b>
Dims Ext	800 (L) x 600 (W)
Weight (kg)	6.7
Material	MDPE

**Dolly Handle for Double Stacking Dolly**

Code	<b>R1165</b>
Dims Ext	948 (L) x 303 (W)
Weight (kg)	2.2
Material	MDPE

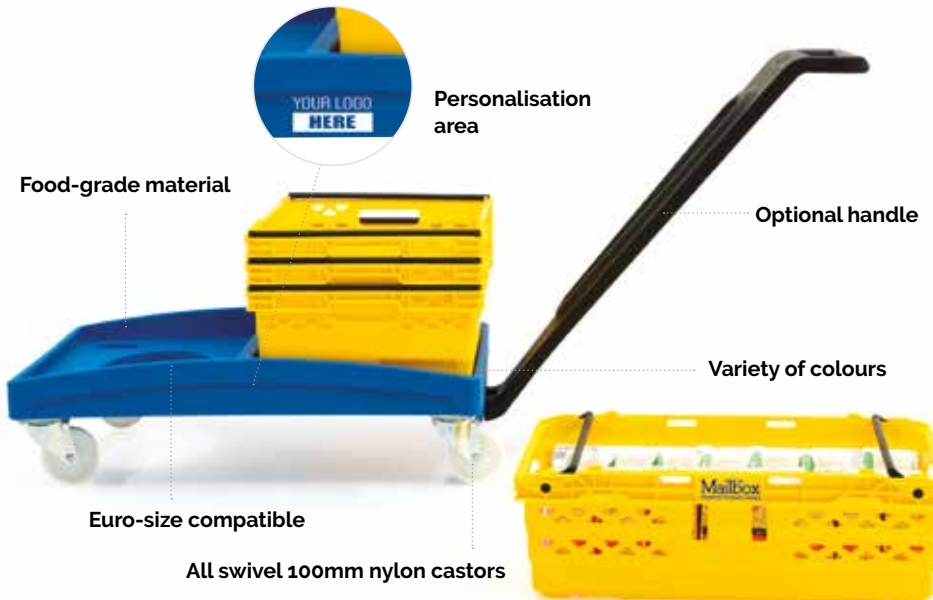

# Attached Lid Boxes

600 x 400mm

Mailbox Products attached lid containers (ALCs) are moulded in food grade virgin polypropylene and are available in a wide range of colours and sizes. They offer all the benefits of our stack/nest containers but with a useful lid. This is ideal for contents that require added protection for their outward journey.

The containers stack safely when full and can be nested after delivery by locating lids in their open position. This saves on valuable distribution and storage space.

- Made of food-grade virgin material
- Integral hinged lid
- Easy to clean
- Robust and durable
- Space-saving
- Stack/nest for easy storage
- Wide range of lid and box colours
- Personalisation options available

600 (L) x 400 (W) x 265 (H) mm  
49.5 Litre Attached Lid Container



Code	M718
Dims Int	530 (L) x 330 (W) x 245 (H) mm
Capacity	49.5 Litres
Weight (kg)	2.6
Material	PP



600 (L) x 400 (W) x 350 (H) mm  
55 Litre Attached Lid Container



Code	M719
Dims Int	503 (L) x 310 (W) x 345 (H) mm
Capacity	68 Litres
Weight (kg)	3.1
Material	PP



## Go Green

New containers from recycled material

Not suitable for direct food contact applications



600 (L) x 400 (W) x 265 (H) mm  
49.5 Litre Recycled Attached Lid Container

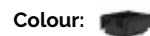

Code	M718 Recycled
Dims Int	530 (L) x 330 (W) x 245 (H) mm
Capacity	49.5 Litres
Weight (kg)	2.6
Material	Recycled PP



600 (L) x 400 (W) x 350 (H) mm  
68 Litre Recycled Attached Lid Container

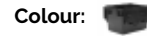

Code	M719 Recycled
Dims Int	503 (L) x 310 (W) x 345 (H) mm
Capacity	68 Litres
Weight (kg)	3.1
Material	Recycled PP





Security Seals (pack of 100)  
Zip tie security seals (pack 100)

Colour: 

Code 022

Length N/A

# ALCs

## 400 x 300 and 600 x 400 RTP solutions

When contents need the added protection of a lid, these attached lid container ALCs are the ideal solution. They provide all the benefits of Mailbox Products stack and nest containers and are ideal for use as return trip packaging.

- Made from a minimum of 30% recycled material
- Integral hinged lid
- Easy to clean
- Space-saving
- Stack / nest for easy storage
- Security seals available for secure transport



**400 (L) x 300 (W) x 264 (H) mm**  
22 Litre Stacking Box - with Solid Sides

<b>Code</b>	<b>U4326</b>
<b>Dims Int</b>	363 (L) x 270 (W) x 245 (H) mm
<b>Capacity</b>	22 Litres
<b>Weight (kg)</b>	1.77
<b>Material</b>	PP



**400 (L) x 300 (W) x 306 (H) mm**  
25 Litre Stacking Box - with Solid Sides

<b>Code</b>	<b>U4330</b>
<b>Dims Int</b>	363 (L) x 270 (W) x 287 (H) mm
<b>Capacity</b>	25 Litres
<b>Weight (kg)</b>	1.92
<b>Material</b>	PP



**600 (L) x 400 (W) x 250 (H) mm**  
40 Litre Stacking Box - with Solid Sides

<b>Code</b>	<b>U6425</b>
<b>Dims Int</b>	547 (L) x 370 (W) x 228 (H) mm
<b>Capacity</b>	40 Litres
<b>Weight (kg)</b>	2.5
<b>Material</b>	PP



**600 (L) x 400 (W) x 310 (H) mm**  
52 Litre Stacking Box - with Solid Sides

<b>Code</b>	<b>U6431</b>
<b>Dims Int</b>	547 (L) x 370 (W) x 288 (H) mm
<b>Capacity</b>	52 Litres
<b>Weight (kg)</b>	2.8
<b>Material</b>	PP



**600 (L) x 400 (W) x 365 (H) mm**  
63 Litre Stacking Box - with Solid Sides

<b>Code</b>	<b>U6436</b>
<b>Dims Int</b>	547 (L) x 370 (W) x 335 (H) mm
<b>Capacity</b>	63 Litres
<b>Weight (kg)</b>	2.85
<b>Material</b>	PP



**600 (L) x 400 (W)**  
Euro ALC Stacking Dolly

<b>Code</b>	<b>U6400</b>
<b>Dims Ext</b>	600 (L) x 400 (W) 173.5 (H)
<b>Deck Type</b>	Open
<b>Weight (kg)</b>	3.3
<b>Material</b>	PP

**600 (L) x 400 (W) x 400 (H) mm**  
69 Litre Stacking Box - with Solid Sides

<b>Code</b>	<b>U6440</b>
<b>Dims Int</b>	547 (L) x 370 (W) x 368 (H) mm
<b>Capacity</b>	69 Litres
<b>Weight (kg)</b>	3.1
<b>Material</b>	PP

Minimum of 30% recycled material

Integral Lid

Robust and durable



Personalisation area



Hand grip

Euro sizes

Stack for easy storage

### Security Seal (pack of 500) Attached Lid Box Security Seal



Colour: **025**



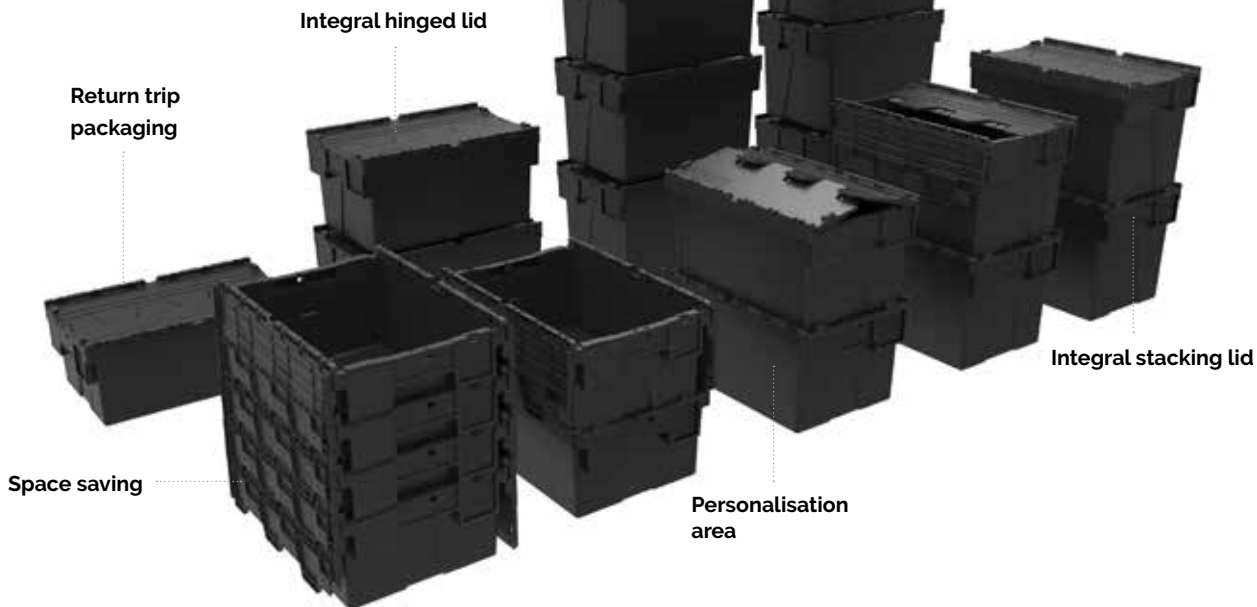

**400 (L) x 300 (W) x 264 (H) mm**  
**22 Litre Stacking Box - with Solid Sides**

<b>Code</b>	<b>U4326R</b>
<b>Dims Int</b>	363 (L) x 270 (W) x 245 (H) mm
<b>Capacity</b>	22 Litres
<b>Weight (kg)</b>	1.77
<b>Material</b>	Recycled PP



**400 (L) x 300 (W) x 306 (H) mm**  
**25 Litre Stacking Box - with Solid Sides**

<b>Code</b>	<b>U4330R</b>
<b>Dims Int</b>	363 (L) x 270 (W) x 287 (H) mm
<b>Capacity</b>	25 Litres
<b>Weight (kg)</b>	1.92
<b>Material</b>	Recycled PP



**600 (L) x 400 (W) x 250 (H) mm**  
**40 Litre Stacking Box - with Solid Sides**

<b>Code</b>	<b>U6425R</b>
<b>Dims Int</b>	547 (L) x 370 (W) x 228 (H) mm
<b>Capacity</b>	40 Litres
<b>Weight (kg)</b>	2.5
<b>Material</b>	Recycled PP



**600 (L) x 400 (W) x 310 (H) mm**  
**52 Litre Stacking Box - with Solid Sides**

<b>Code</b>	<b>U6431R</b>
<b>Dims Int</b>	547 (L) x 370 (W) x 288 (H) mm
<b>Capacity</b>	52 Litres
<b>Weight (kg)</b>	2.8
<b>Material</b>	Recycled PP



**600 (L) x 400 (W) x 365 (H) mm**  
**63 Litre Stacking Box - with Solid Sides**

<b>Code</b>	<b>U6436R</b>
<b>Dims Int</b>	547 (L) x 370 (W) x 335 (H) mm
<b>Capacity</b>	63 Litres
<b>Weight (kg)</b>	2.8
<b>Material</b>	Recycled PP



**600 (L) x 400 (W) x 400 (H) mm**  
**69 Litre Stacking Box - with Solid Sides**

<b>Code</b>	<b>U6440R</b>
<b>Dims Int</b>	547 (L) x 370 (W) x 368 (H) mm
<b>Capacity</b>	69 Litres
<b>Weight (kg)</b>	3.1
<b>Material</b>	Recycled PP



## Interstacking Bins

18 - 73 litres

Mailbox Products interstacking round bins come in four sizes. They are popular across many industries, particularly the food industry. Manufactured from virgin material, they are commonly used for the storage and handling of food ingredients such as sugar and flour.

- Stack for easy storage
- Made of food-grade virgin material
- Personalisation options available

430 (D) x 180 (H) mm  
18 Litre Stacking Bin



Code	X353
Dims Int	350 (D) x 170 (H) mm
Capacity	18 Litres
Weight (kg)	1.4
Material	MDPE
Drop on Lid	E8830

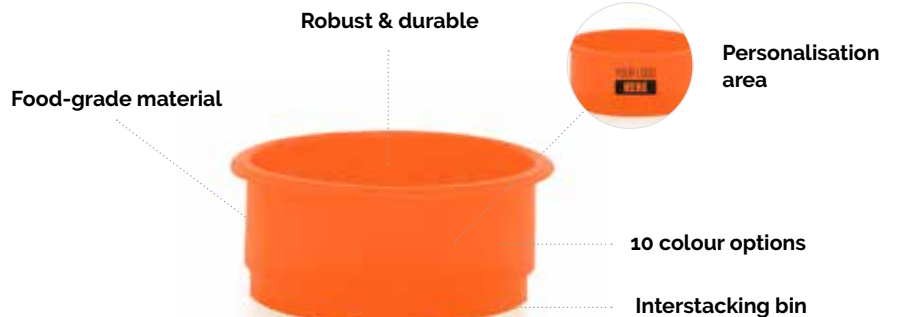



430 (D) x 290 (H) mm  
30 Litre Stacking Bin



**Code** X354  
**Dims Int** 350 (D) x 285 (H) mm  
**Capacity** 30 Litres  
**Weight (kg)** 2.0  
**Material** MDPE  
**Drop on Lid** E8830



430 (D) x 450 (H) mm  
45 Litre Stacking Bin



**Code** X355  
**Dims Int** 350 (D) x 440 (H) mm  
**Capacity** 45 Litres  
**Weight (kg)** 2.5  
**Material** MDPE  
**Drop on Lid** E8830



430 (D) x 635 (H) mm  
73 Litre Stacking Bin



**Code** X356  
**Dims Int** 350 (D) x 625 (H) mm  
**Capacity** 73 Litres  
**Weight (kg)** 4.2  
**Material** MDPE  
**Drop on Lid** E8830



430 (D) x 15 (H) mm  
Lid for use with X353 X354 X355 & X356



**Code** E8830  
**Weight (kg)** 0.6  
**Material** MDPE



500 (L) x 500 (W) x 268 (H) mm  
Dolly for with X353 X354, X355, X356 & E537 & X300



**Code** R1255  
**Dims Int** 455 (L) x 445 (W) x 182 (H) mm  
**Load weight (kg)** 250  
**Weight (kg)** 3.8  
**Material** MDPE



Aperture Height: 180mm  
Aperture Dia: 385mm

500 (L) x 500 (W) x 268 (H) mm Double dolly  
for with X353 X354, X355, X356 & E537 & X300



**Code** H1255  
**Dims Int** 455 (L) x 445 (W) x 182 (H) mm  
**Load weight (kg)** 250  
**Weight (kg)** 12.2  
**Dolly Material** 304 Stainless Steel  
**Insert Material** MDPE

Stainless Steel 304

MDPE food-grade material

Collecting and transporting bins



Aperture Height: 57mm  
Aperture Dia: 385mm



Reduce manual handling and safely transport bins with trolley recess

Fitted with 100mm nylon swivel castors

1050 (L) x 800 (W) x 950 (H) mm Quad Dolly  
for use with X353 X354, X355, X356 & E537 & X300

Colour:

Code	H1455
Platform Dims	906 (L) x 906 (W) x 165 (H) mm
Load weight (kg)	250
Weight (kg)	22.4
Dolly Material	304 Stainless Steel
Insert Material	MDPE

Reduce manual handling and safely transport bins with trolley recess

Stainless Steel 304

MDPE food-grade material

Aperture Height: 57mm  
Aperture Dia: 385mm

Collecting and transporting bins

Fitted with 100mm nylon swivel castors

## Buckets with Handles

15 - 31 Litres

Mailbox Products round nesting bins come in several sizes to suit your needs exactly. These rotational-moulded round bins are suitable for a wide range of applications, including food contact. They nest when not in use to save on space.

- Made of food-grade virgin material
- Nest for easy storage
- Easy to clean, robust and durable
- Personalisation options available



340 (D) x 350 (H) mm  
15 Litre Bin with Stainless Steel Handle

Colour:

Code	R1170B
Dims Int	220 (D) x 340 (H) mm
Capacity	15 Litres
Weight (kg)	1.4
Material	MDPE
Drop on Lid	E8577



380 (D) x 450 (H) mm  
22 Litre Bin with Stainless Steel Handle

Colour:

Code	E577B
Dims Int	280 (D) x 430 (H) mm
Capacity	22 Litres
Weight (kg)	1.6
Material	MDPE
Drop on Lid	E8577



450 (D) x 450 (H) mm  
31 Litre Bin with Stainless Steel Handle

Colour:

Code	E575B
Dims Int	340 (D) x 430 (H) mm
Capacity	31 Litres
Weight (kg)	2.1
Material	MDPE
Drop on Lid	E8575



# Tapered Nesting Bins

67 - 225 litres

Tapered nesting bins can be used across many industries. Available in a wide range of colours, they are ideal for colour-coding and food segregation. They are very strong, with smooth construction for easy cleaning and outstanding hygiene.

Personalisation options, such as printing logos, text, sequential numbering and product identification gives a more bespoke solution to suit your requirements.

- Made of food-grade virgin material
- Nest for easy storage
- Easy to clean, robust and durable
- Personalisation options available



480 (D) x 490 (H) mm  
47 Litre Bin with Handle

Colour:

Code	X329
Dims Int	309 (D) x 475 (H) mm
Capacity	47 Litres
Weight (kg)	2.2
Material	MDPE
Drop on Lid	X345



540 (D) x 520 (H) mm  
68 Litre Bin with Handle

Colour:

Code	M14B
Dims Int	352 (D) x 490 (H) mm
Capacity	68 Litres
Weight (kg)	4.1
Material	PP
Drop on Lid	X301



550 (D) x 690 (H) mm  
90 Litre Tapered Nesting Bin

Colour:

Code	X300
Dims Int	380 (D) x 670 (H) mm
Capacity	90 Litres
Weight (kg)	3.5
Material	MDPE
Drop on Lid	X301



570 (D) x 780 (H) mm  
125 Litre Tapered Nesting Bin

Colour:

Code	E573
Dims Int	440 (D) x 760 (H) mm
Capacity	125 Litres
Weight (kg)	6.7
Material	MDPE
Drop on Lid	E8573

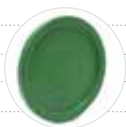

690 (D) x 910 (H) mm  
225 Litre Tapered Nesting Bin

Colour:

Code	X332
Dims Int	690 (D) x 910 (H) mm
Capacity	225 Litres
Weight (kg)	9.0
Material	MDPE
Drop on Lid	X333

Personalisation options available



We offer a wide range of product personalisation options for a truly bespoke experience – your graphics, your text, our products.

# Rectangular Bins

30 - 136 litres bins

Mailbox Products rectangular plastic tanks and bins are available in a range of sizes. These heavy-duty containers are especially suited to the food industry as their smooth surface makes them easy to clean.

To view our full range, visit our website [www.mailboxproducts.co.uk](http://www.mailboxproducts.co.uk).

- Available in a variety of capacities
- Made of food-grade virgin polyethylene
- Robust and durable
- Smooth internal surfaces
- Personalisation options available



**330 (L) x 230 (W) x 600 (H) mm**  
34 Litre Rectangular Food Container



<b>Code</b>	<b>E318</b>
<b>Dims Int</b>	395 (L) x 300 (W) x 225 (H) mm
<b>Capacity</b>	30 Litres
<b>Weight (kg)</b>	2.4
<b>Material</b>	MDPE



**480 (L) x 390 (W) x 260 (H) mm**  
34 Litre Rectangular Food Container



<b>Code</b>	<b>X338</b>
<b>Dims Int</b>	395 (L) x 300 (W) x 225 (H) mm
<b>Capacity</b>	34 Litres
<b>Weight (kg)</b>	1.8
<b>Material</b>	MDPE
<b>Drop-on Lid</b>	X8338



**520 (L) x 440 (W) x 365 (H) mm**  
98 Litre Rectangular Food Container



<b>Code</b>	<b>X326</b>
<b>Dims Int</b>	430 (L) x 350 (W) x 330 (H) mm
<b>Capacity</b>	52 Litres
<b>Weight (kg)</b>	2.6
<b>Material</b>	MDPE



**430 (L) x 430 (W) x 570 (H) mm**  
68 Litre Rectangular Nesting Bin



<b>Code</b>	<b>E763</b>
<b>Dims Int</b>	310 (L) x 310 (W) x 560 (H) mm
<b>Capacity</b>	68 Litres
<b>Weight (kg)</b>	4.0
<b>Material</b>	MDPE
<b>Drop-on Lid</b>	E8763



**430 (L) x 430 (W) x 10 (H) mm**  
Drop-on Lid for E763



<b>Code</b>	<b>E8763</b>
<b>Dims Ext</b>	430 (L) x 430 (W) x 10 (H) mm
<b>Weight (kg)</b>	1.1
<b>Material</b>	MDPE



**530 (L) x 530 (W) x 10 (H) mm**  
Drop-on Lid for E817

<b>Code</b>	<b>E8817</b>
<b>Dims Ext</b>	530 (L) x 530 (W) x 10 (H) mm
<b>Weight (kg)</b>	1.1
<b>Material</b>	MDPE



**530 (L) x 530 (W) x 690 (H) mm**  
136 Litre Rectangular Bin Nesting Tank



<b>Code</b>	<b>E817</b>
<b>Dims Int</b>	410 (L) x 410 (W) x 670 (H) mm
<b>Capacity</b>	136 Litres
<b>Weight (kg)</b>	5.6
<b>Material</b>	MDPE
<b>Drop-on Lid</b>	E8817





# Ingredients Trolleys

Popular in commercial and plant bakeries

Ingredients trolleys are designed to allow easy filling and dispensing but also have lids to protect contents and prevent spills, smells and cross-contamination.

- **Stainless steel or epoxy-coated mild steel**
- **Easy-to-manoevre 100mm nylon castors**
- **Robust and durable**



**500 (L) x 455 (W) x 1230 (H) mm**  
**3 Bin Mild Steel Ingredients Trolley - For use with 3 x X338 Bins**

<b>Code</b>	<b>H3338</b>
<b>Dims Ext</b>	500 (L) x 455 (W) x 1230 (H) mm
<b>Castors</b>	100mm
<b>Weight (kg)</b>	12
<b>Material</b>	Mild Steel



**500 (L) x 455 (W) x 1230 (H) mm**  
**3 Bin Stainless Steel Ingredients Trolley - For use with 3 x X338 Bins**

<b>Code</b>	<b>H3338SS</b>
<b>Dims Ext</b>	500 (L) x 455 (W) x 1230 (H) mm
<b>Castors</b>	100mm
<b>Weight (kg)</b>	12
<b>Material</b>	Stainless Steel



**900 (L) x 500 (W) x 1260 (H) mm**  
**6 Bin Mild Steel Ingredients Trolley - For use with 6 x X338 Bins**

<b>Code</b>	<b>H6338</b>
<b>Dims Ext</b>	900 (L) x 500 (W) x 1260 (H) mm
<b>Castors</b>	100mm
<b>Weight (kg)</b>	22
<b>Material</b>	Mild Steel



Robust and easy to clean

X338 Ingredient dispensers

Sloped holders

Easy to manoeuvre

Smooth internal surfaces

Stainless steel or epoxy-coated mild steel

**900 (L) x 500 (W) x 1260 (H) mm**  
**6 Bin Stainless Steel Ingredients Trolley - For use with 6 x X338 Bins**

<b>Code</b>	<b>H6338SS</b>
<b>Dims Ext</b>	900 (L) x 500 (W) x 1260 (H) mm
<b>Castors</b>	100mm
<b>Weight (kg)</b>	22
<b>Material</b>	Stainless Steel



Personalisation options available

We offer a wide range of product personalisation options for a truly bespoke experience – your graphics, your text, our products.



100mm nylon castors



## Rectangular Tanks 468 - 643 litres

Mailbox Products rectangular plastic tanks and bins are available in a range of sizes, and offer a generous capacity of up to 643 litres. Optional static and mobile frames are available, including bespoke units to suit application.

- Made from food-grade materials
- Easy to clean tanks
- Robust and durable
- Personalisation options



1145 (L) x 800 (W) x 780 (H) mm  
468 Litre - Large Rectangular  
Stacking Tank

Colour: 

**Tank code** E749  
**Frame code** H749 STATIC  
**Dims Int** 980 (L) x 660 (W) x 690 (H) mm  
**Capacity** 468 Litres  
**Weight (kg)** 21.5  
**Material** MDPE



1360 (L) x 900 (W) x 740 (H) mm  
582 Litre - Large Rectangular  
Stacking Tank

Colour: 

**Tank code** E771  
**Frame code** H771 STATIC  
**Dims Int** 1130 (L) x 900 (W) x 740 (H) mm  
**Capacity** 582 Litres  
**Weight (kg)** 24.5  
**Material** MDPE



1700 (L) x 890 (W) x 880 (H) mm  
643 Litre - Large Rectangular  
Stacking Tank

Colour:  

**Tank code** E770  
**Frame code** H770M MOBILE  
**Dims Int** 1350 (L) x 730 (W) x 610 (H) mm  
**Capacity** 643 Litres  
**Weight (kg)** 49  
**Material** MDPE



# Maximover IBC

Up to 3000 litres

Transform your storage and handling operations with these robust UK-manufactured containers.

- Units available from 200L-3000L, 0.227-3 m3
- Large range of lids and valves
- Material colour options
- Painted, galvanised or stainless steel frames

## KLC RANGE: LIQUID IBC - All-round Maximover from 600 to 2000 litres

Inherently strong cylindrical construction for the handling and transportation of bulk liquids of high s.g. or high viscosity.

All units have a choice of 2" / 3" vertical or horizontal, flanged or spigot outlet.

Code	Capacity	Height	Width	Depth	Material
KLC0600	600 litres	1440mm	1220mm	1220mm	MDPE
KLC1000	1000 litres	1846mm	1220mm	1220mm	MDPE
KLC1500	1500 litres	2290mm	1220mm	1220mm	MDPE
KLC2000	2000 litres	2740mm	1220mm	1220mm	MDPE

Every Mailbox Maximover IBC unit is unique - specifically designed to fulfil each client's expectations..

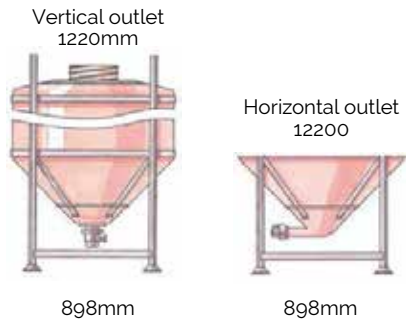

## KLS RANGE: LIQUID IBC - Capacities from 500 - 3000 litres

Standard fittings: 350mm screw lid with 2" single union ball valve for liquids. Optional galvanised frame for extended external use.

Code	Capacity	Height	Width	Depth	Material
KLS0500	500 litres	1280mm	1181mm	1181mm	MDPE
KLS0750	750 litres	1480mm	1181mm	1181mm	MDPE
KLS1000	1000 litres	1680mm	1181mm	1181mm	MDPE
KLS1250	1250 litres	1880mm	1181mm	1181mm	MDPE
KLS1500	1500 litres	2080mm	1181mm	1181mm	MDPE
KLS1750	1750 litres	2280mm	1181mm	1181mm	MDPE
KLS2000	2000 litres	2480mm	1181mm	1181mm	MDPE
KLS2250	2250 litres	2680mm	1181mm	1181mm	MDPE
KLS2500	2500 litres	2880mm	1181mm	1181mm	MDPE
KLS2750	2750 litres	3080mm	1181mm	1181mm	MDPE
KLS3000	3000 litres	3280mm	1181mm	1181mm	MDPE



## KLS 0430: LIQUID IBC - 90° CONE-LIQUIDS

Standard fittings: 350mm screw lid with 2" single union ball valve for liquids. Optional galvanised frame for extended external use.

Code	Capacity	Height	Width	Depth	Material
KLS0430	430 litres	1538mm	743mm	743mm	MDPE

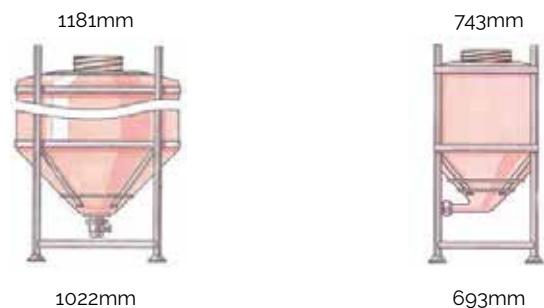

## Free production line assessment

Storage area assessment from our materials handling representatives to help produce bespoke solutions implementing the best practices.

**NON-HAZARDOUS SOLID: KSS-90° CONE (200mm outlet)**

Standard fittings: 480mm (PE) clamp lid with galvanised band. 200mm double flanged slide valve and transit cap.

Code	Capacity	Height	Width	Depth	Material
KSS1500	1.5 Cu. m	2030mm	1181mm	1181mm	MDPE



KLS1500

**NON-HAZARDOUS SOLID: KSS - 90° & 60° CONES (200mm & 300mm outlet)**

Standard fittings - Modular unit: 350mm screw lid with 90° & 60° single flanged slide valve. Optional galvanised frame for extended external use.

Code	Capacity	90° cone 200mm outlet	60° cone 300mm outlet	60° cone 200mm outlet	Width	Depth	Material
KSS0500	0.50 Cu. m	1260mm	1480mm	N/A	1181mm	1181mm	MDPE
KSS0750	0.75 Cu. m	1460mm	1680mm	1880mm	1181mm	1181mm	MDPE
KSS1000	1.00 Cu. m	1660mm	1830mm	2080mm	1181mm	1181mm	MDPE
KSS1250	1.25 Cu. m	1860mm	2030mm	2280mm	1181mm	1181mm	MDPE
KSS1500	1.50 Cu. m	2060mm	2230mm	2480mm	1181mm	1181mm	MDPE
KSS1750	1.75 Cu. m	2260mm	2480mm	2680mm	1181mm	1181mm	MDPE
KSS2000	2.00 Cu. m	2460mm	2680mm	2880mm	1181mm	1181mm	MDPE
KSS2250	2.25 Cu. m	2660mm	2880mm	3080mm	1181mm	1181mm	MDPE
KSS2500	2.50 Cu. m	2860mm	3080mm	3280mm	1181mm	1181mm	MDPE
KSS2750	2.75 Cu. m	3060mm	3280mm	3480mm	1181mm	1181mm	MDPE
KSS3000	3.00 Cu. m	3260mm	3480mm	3680mm	1181mm	1181mm	MDPE



KSS RANGE

90° cone 200mm outlet    60° cone 300mm outlet    60° cone 200mm outlet

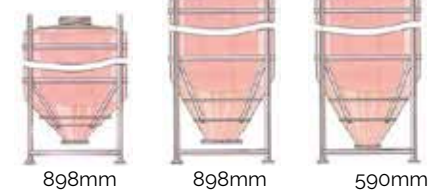

**NON-HAZARDOUS SOLID: IBC KSC- 90° & 60° CONES (200mm & 300mm outlet)**

Standard fittings - Circular Unit: 350mm screw lid with 200mm / 300mm single flanged side valve. Optional galvanised frame for extended external use.

Code	Capacity	90° cone 200mm outlet	60° cone 300mm outlet	Width	Depth	Material
KSC0600	0.60 Cu. m	1365mm	1395mm	1220mm	1220mm	MDPE
KSC1000	1.00 Cu. m	1771mm	1810mm	1220mm	1220mm	MDPE
KSC1500	1.50 Cu. m	2215mm	2245mm	1220mm	1220mm	MDPE
KSC2000	2.00 Cu. m	2665mm	2695mm	1220mm	1220mm	MDPE

**NON-HAZARDOUS SOLIDS: KSC 0227 (200mm outlet)**

Standard fittings: 350mm screw lid with 200mm single flanged slide valve. Optional galvanised frame for extended external use.

Code	Capacity	Height	Width	Depth	Material
KSC0227	0.227 Cu. m	1073mm	806mm	806mm	MDPE



KLC RANGE

KSC0227

90° cone 200mm outlet 1220mm    60° cone 300mm outlet 1220mm



898mm

898mm

590mm

**Personalisation options available**

We offer a wide range of product personalisation options for a truly bespoke experience – your graphics, your text, our products.

# Pallet Tanks

Designed to meet the highest hygiene standards, including smooth interior and rounded corners.

Pallet tanks are reusable, multi-use, industrial-grade containers engineered for the mass handling, transport and storage of liquids, semi-solids, pastes or solids. They offer strength and durability and are seen across a variety of industries including logistics, waste and recycling, food and agriculture.

- Heavy duty tanks
- Strong and robust
- Easy to clean
- Colour-coded
- Personalisation available



**1200 (L) x 800 (W) x 740 (H) mm**  
**500 Litre Pallet Tank 4 Way Entry - 2 Boxed**  
**2 Open with Solid Sides & Base**



<b>Code</b>	<b>D1208A</b>
<b>Dims Int</b>	1120 (L) x 720 (W) x 600 (H) mm
<b>Capacity</b>	500 Litres
<b>Weight (kg)</b>	32.0
<b>Material</b>	HDPE
<b>Drop-on Lid</b>	D8208

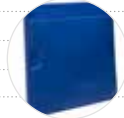

**1200 (L) x 1000 (W) x 740 (H) mm**  
**600 Litre Pallet Tank 4 Way Entry - 2 Boxed**  
**2 Open with Solid Sides & Base Container**



<b>Code</b>	<b>D1210A</b>
<b>Dims Int</b>	1120 (L) x 920 (W) x 600 (H) mm
<b>Capacity</b>	600 Litres
<b>Weight (kg)</b>	37.0
<b>Material</b>	HDPE
<b>Drop-on Lid</b>	D8210

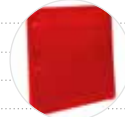

**1200 (L) x 800 (W) x 20 (H) mm**  
**Pallet Tank Lid for use with D1210A**

Colour:

<b>Code</b>	<b>D8208</b>
<b>Dims Ext</b>	1200 (L) x 800 (W) x 20 (H) mm
<b>Weight (kg)</b>	5.4
<b>Material</b>	MDPE



**1200 (L) x 1000 (W) x 20 (H) mm**  
**Pallet Tank Lid for use with D1210A**

Colour:

<b>Code</b>	<b>D8210</b>
<b>Dims Ext</b>	1200 (L) x 1000 (W) x 20 (H) mm
<b>Weight (kg)</b>	5.6
<b>Material</b>	MDPE

Bulk storage across a wide range of industries



1290 (L) x 1030 (W) x 720 (H) mm  
795 Litre Nesting Pallet Tank With Solid Sides & Base



Code	E2
Dims Int	1140 (L) x 900 (W) x 720 (H) mm
Capacity	795 Litres
Weight (kg)	40.0
Material	MDPE
Drop-on Lid	E8002



Nesting pallet tank Robust & durable

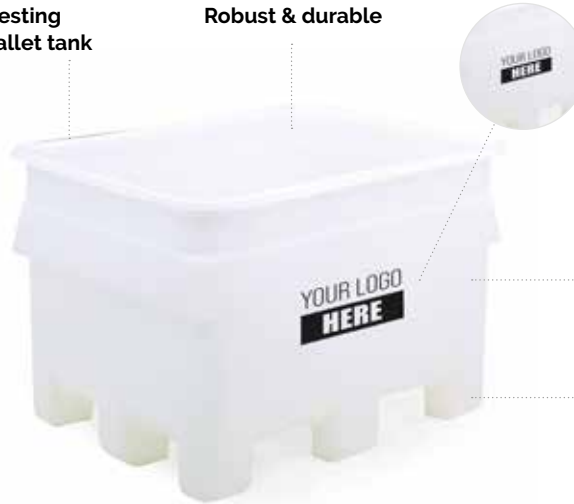

Printed logos, text and sequential numbering

Industrial-grade

Wide selection of colours



1200 (L) x 800 (W) x 920 (H) mm  
600 Litre Nesting Pallet Tank 4 Way Entry - 4 Open Euro Size Nesting Pallet Tank



Code	R1072
Dims Int	1020 (L) x 620 (W) x 790 (H) mm
Capacity	600 Litres
Weight (kg)	28.0
Material	MDPE
Drop-on Lid	R1073

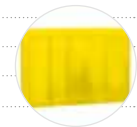

1300 (L) x 1030 (W) x 10 (H) mm  
Pallet Tank Lid for use with E2



Code	E8002
Dims Ext	1300 (L) x 1030 (W) x 10 (H) mm
Weight (kg)	12
Material	MDPE

1200 (L) x 800 (W) x 15 (H) mm  
Pallet Tank Lid for use with R1072



Code	R1073
Dims Ext	1200 (L) x 800 (W) x 15 (H) mm
Weight (kg)	10
Material	MDPE



925 (L) x 925 (W) x 1100 (H) mm  
586 Litre Pallet Tank 4 Way Entry - 2 Boxes 2 Open - Twin Skinned Pallet Tank



Code	R338
Dims Int	820 (L) x 820 (W) x 925 (H) mm
Capacity	586 Litres
Weight (kg)	68.7
Material	MDPE



1220 (L) x 1040 (W) x 1200 (H) mm  
1089 Litre Pallet Tank 4 Way Entry - 4 Open



Code	R1169
Dims Int	1030 (L) x 850 (W) x 1043 (H) mm
Capacity	1089 Litres
Weight (kg)	54
Material	MDPE

Personalisation options available

We offer a wide range of product personalisation options for a truly bespoke experience – your graphics, your text, our products.



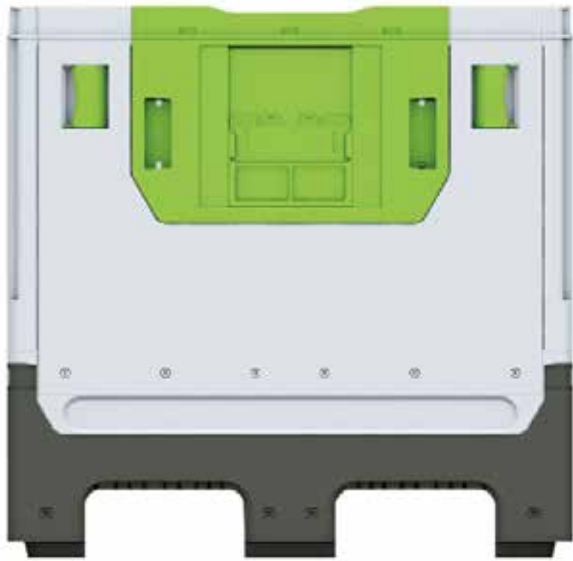

975 mm Single Height

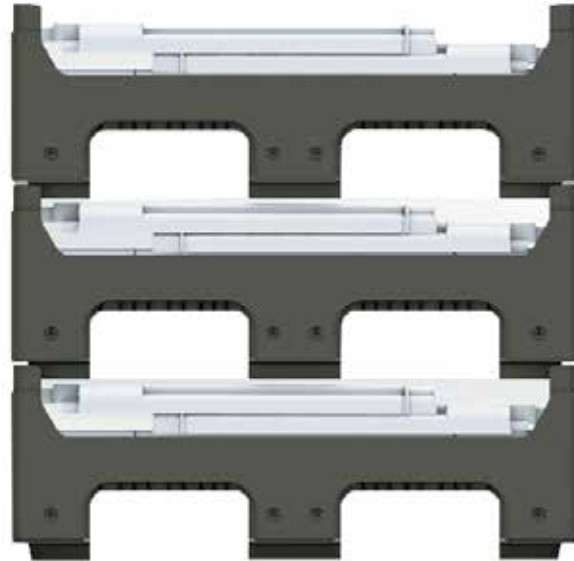

345 mm Single Folding Height  
315 mm Stacking Folding Height

## Foldable Large Container (FLC)

The K975 is the perfect solution to modern packaging needs. Made of the highest quality food-grade plastic, K975 offers a large amount of storage and folds quickly and easily when not needed, with up to eight pallets stacking tidily on top of each other in just one pallet space.

**1200 (L) x 1000 (W) x 975 (H) mm**  
Foldable Large Container

**Colour:** Side panels: Grey 429C ● Base: Black ● Drop door: Green 368C ●

<b>Code</b>	K975
<b>Dims Int</b>	1130 (L) x 930 (W) x 815 (H) mm
<b>Weight (kg)</b>	58
<b>Material</b>	Food grade polypropylene
<b>Drop-on Lid</b>	K8975

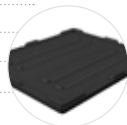

**Label holders**  
Identify contents easily, with convenient label holders on two sides.



**Non-sequential folding**  
Flexible hinges allow non-sequential folders to save time and energy.

- Outstanding folding ratio
- Double wall construction
- Ideal across all industries
- Works seamlessly with automated systems
- Reinforced base
- Protects fragile contents
- Strong and long-lasting
- Easy to clean
- Compatible with most existing containers



**Unique interlocking design**  
Interlocking sides ensure easy, fast and secure erection.

**Safety**  
Chamfer design prevents operator injury.



<b>MATERIAL:</b>	Food Grade Polypropylene
<b>STACK/NEST TYPE:</b>	Folding
<b>FOLDING RATE:</b>	3:1
<b>DYNAMIC LOAD</b>	1300 Kg
<b>STATIC LOAD</b>	3300 Kg
<b>UNIT LOAD</b>	+500 Kg
<b>TARE WEIGHT</b>	58 Kg

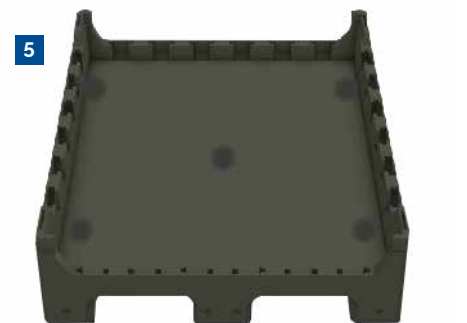
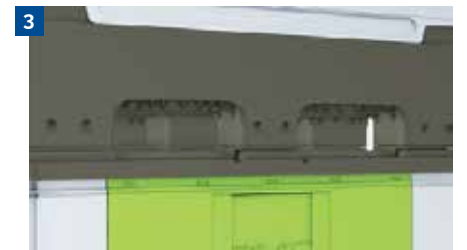

Mailbox has one of the widest ranges of materials handling solutions in Europe. The K975 is an exciting addition to our portfolio.

Sleek, modern appearance, strong construction, maximum space efficiency and clever design bring a raft of benefits to any logistics systems.

- 1 Drop door:** For quick and easy loading and unloading.
- 2 Hidden hinges:** Smooth, hygiene internal design ensures maximum space efficiency.
- 3 Secure fitting lid:** Ensure contents is protected from damage, dirt, water etc.
- 4 Stacking compatibility:** Curved skid guarantees compatibility with most other containers. Reinforced rib design on base increases load capacity.
- 5 Drainage system:** Base drainage systems maximizes water evacuation following rain or cleaning.



## Go Green

New containers from recycled material

Not suitable for direct food contact applications

496 (L) x 297 (W) x 250 (H) mm

24 Litre Shopping Baskets

UK Manufactured Retail Shopping Baskets

Code M726R

Dims Int 375 (L) x 190 (W) x 210 (H) mm

Capacity 24 Litres

Weight (kg) 0.67

Material Recycled PP

**Mailbox**  
www.mailboxproducts.co.uk



## Retail Shopping Basket UK manufactured

Mailbox Products nesting plastic shopping baskets are nestable for easy storage. Robust design means they are suitable for use in a wide variety of environments, including shops and garden centres. They are also ideal for non-retail areas such as schools and offices.

- Made from food-grade materials
- Stowaway handle
- Robust and durable
- Nests for easy storage



496 (L) x 297 (W) x 250 (H) mm  
24 Litre Shopping Baskets

Colour:

**Code** M726  
**Dims Int** 375 (L) x 190 (W) x 210 (H) mm  
**Capacity** 24 Litres  
**Weight (kg)** 0.67  
**Material** PP

515 (L) x 500 (W) x 770 (H) mm  
Steel Mobile Shopping Basket Holder

**Code** H726A  
**Dims Ext** 515 (L) x 500 (W) x 770 (H) mm  
**Weight (kg)** 0.8  
**Material** Zinc Plated

# Moulded Trucks

115 - 450 litres

For moving large amounts of product from A to B, Mailbox Products moulded trucks are invaluable. Strong casters ensure stability. The trucks offer generous capacities and have optional lids for extra protection of contents.

Some models are available with a handle for even greater manoeuvrability. The wide range of bright colour options makes them suitable for use with colour-coded segregation systems.

- Made from food-grade materials
- Large capacity trucks
- Easy to manoeuvre
- Easy to clean
- Robust and durable
- Personalisation area



605 (L) x 510 (W) x 590 (H) mm  
115 Litre Moulded Truck & Lid



<b>Code</b>	<b>R930</b>
<b>Dims Int</b>	520 (L) x 435 (W) x 430 (H) mm
<b>Capacity</b>	115 Litres
<b>Weight (kg)</b>	6.1
<b>Material</b>	MDPE
<b>Castors</b>	100mm swivel nylon



600 (L) x 510 (W) x 686 (H) mm  
131 Litre Moulded Truck



<b>Code</b>	<b>R932</b>
<b>Dims Int</b>	500 (L) x 410 (W) x 580 (H) mm
<b>Capacity</b>	131 Litres
<b>Weight (kg)</b>	8.2
<b>Material</b>	MDPE
<b>Castors</b>	100mm swivel nylon
<b>Drop-on Lid</b>	R8932



680 (L) x 460 (W) x 660 (H) mm  
135 Litre Moulded Truck



<b>Code</b>	<b>E970</b>
<b>Dims Int</b>	530 (L) x 305 (W) x 580 (H) mm
<b>Capacity</b>	135 Litres
<b>Weight (kg)</b>	8.3
<b>Material</b>	MDPE
<b>Castors</b>	75mm swivel nylon
<b>Drop-on Lid</b>	E8970



745 (L) x 460 (W) x 865 (H) mm  
135 Litre Moulded Truck With Handle



<b>Code</b>	<b>E970H</b>
<b>Dims Int</b>	530 (L) x 305 (W) x 580 (H) mm
<b>Capacity</b>	135 Litres
<b>Weight (kg)</b>	9.5
<b>Material</b>	MDPE
<b>Castors</b>	75mm swivel nylon



930 (L) x 460 (W) x 750 (H) mm  
214 Litre Moulded Truck



<b>Code</b>	<b>E969</b>
<b>Dims Int</b>	810 (L) x 350 (W) x 610 (H) mm
<b>Capacity</b>	214 Litres
<b>Weight (kg)</b>	10.5
<b>Material</b>	MDPE
<b>Castors</b>	75mm swivel nylon
<b>Drop-on Lid</b>	E8969



1000 (L) x 460 (W) x 905 (H) mm  
214 Litre Moulded Truck With Handle



<b>Code</b>	<b>E969H</b>
<b>Dims Int</b>	810 (L) x 350 (W) x 610 (H) mm
<b>Capacity</b>	214 Litres
<b>Weight (kg)</b>	11.7
<b>Material</b>	MDPE
<b>Castors</b>	75mm swivel nylon

Trolley

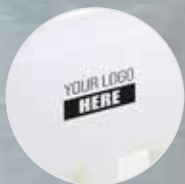

Printed logos, text  
and sequential numbering



875 (L) x 710 (W) x 635 (H) mm  
227 Litre Moulded Truck



<b>Code</b>	<b>Rg67</b>
<b>Dims Int</b>	665 (L) x 510 (W) x 475 (H) mm
<b>Capacity</b>	227 Litres
<b>Weight (kg)</b>	13
<b>Material</b>	MDPE
<b>Castors</b>	100mm swivel nylon 2 fixed, 2 swivel
<b>Drop-on Lid</b>	R8967



970 (L) x 710 (W) x 760 (H) mm  
227 Litre Moulded Truck With Handle



<b>Code</b>	<b>Rg67H</b>
<b>Dims Int</b>	870 (L) x 530 (W) x 600 (H) mm
<b>Capacity</b>	227 Litres
<b>Weight (kg)</b>	14.9
<b>Material</b>	MDPE
<b>Castors</b>	100mm swivel nylon 2 fixed, 2 swivel



970 (L) x 670 (W) x 710 (H) mm  
304 Litre Moulded Truck



<b>Code</b>	<b>Eg68</b>
<b>Dims Int</b>	830 (L) x 520 (W) x 610 (H) mm
<b>Capacity</b>	304 Litres
<b>Weight (kg)</b>	15.6
<b>Material</b>	MDPE
<b>Castors</b>	100mm swivel nylon 2 fixed, 2 swivel
<b>Drop-on Lid</b>	E8968



1070 (L) x 670 (W) x 880 (H) mm  
304 Litre Moulded Truck with Handle



<b>Code</b>	<b>Eg68H</b>
<b>Dims Int</b>	830 (L) x 520 (W) x 610 (H) mm
<b>Capacity</b>	304 Litres
<b>Weight (kg)</b>	16.8
<b>Material</b>	MDPE
<b>Castors</b>	100mm swivel nylon 2 fixed, 2 swivel



1290 (L) x 700 (W) x 740 (H) mm  
450 Litre Moulded Truck



<b>Code</b>	<b>Eg72</b>
<b>Dims Int</b>	1140 (L) x 520 (W) x 610 (H) mm
<b>Capacity</b>	450 Litres
<b>Weight (kg)</b>	22.5
<b>Material</b>	MDPE
<b>Castors</b>	100mm swivel nylon 2 fixed, 2 swivel
<b>Drop-on Lid</b>	E8972



1350 (L) x 680 (W) x 940 (H) mm  
450 Litre Moulded Truck with Handle



<b>Code</b>	<b>Eg72H</b>
<b>Dims Int</b>	1140 (L) x 520 (W) x 610 (H) mm
<b>Capacity</b>	450 Litres
<b>Weight (kg)</b>	23.7
<b>Material</b>	MDPE
<b>Castors</b>	100mm swivel nylon 2 fixed, 2 swivel





1140 (L) x 520 (W) x 10 (H) mm  
Drop on Moulded Truck Lid for E972



Code	E8972
Dims Ext	1140 (L) x 520 (W) x 10 (H) mm
Weight (kg)	4.0
Material	MDPE



970 (L) x 670 (W) x 10 (H) mm  
Drop on Moulded Truck Lid for E968 & E968B



Code	E8968
Dims Ext	970 (L) x 670 (W) x 10 (H) mm
Weight (kg)	3.0
Material	MDPE



600 (L) x 510 (W) x 10 (H) mm  
Drop on Moulded Truck Lid for R932



Code	R8932
Dims Ext	600 (L) x 510 (W) x 10 (H) mm
Weight (kg)	1.3
Material	MDPE



680 (L) x 460 (W) x 10 (H) mm  
Drop on Moulded Truck Lid for E970



Code	E8970
Dims Ext	680 (L) x 460 (W) x 10 (H) mm
Weight (kg)	1.0
Material	MDPE



930 (L) x 460 (W) x 10 (H) mm  
Drop on Moulded Truck Lid for E969



Code	E8969
Dims Ext	930 (L) x 460 (W) x 10 (H) mm
Weight (kg)	1.6
Material	MDPE



875 (L) x 675 (W) x 10 (H) mm  
Drop on Moulded Truck Lid for R967



Code	R8967
Dims Ext	875 (L) x 675 (W) x 10 (H) mm
Weight (kg)	2.0
Material	MDPE

Suitable for food-approved use



**Mailbox**  
www.mailboxproducts.co.uk

# Bottle Trucks

High-quality construction and a generous capacity

Mailbox Products industrial bottle trucks are ideal for collecting, transporting and storing empty bottles or other products in environments such as restaurants, bars, pubs, hotels and function venues. Smooth construction ensures easy cleaning, which is essential for food-related use.

- Large capacity
- Easy to clean
- Robust and durable
- Support hygienic recycling
- Easy to manoeuvre
- Personalisation options available

MDPE food-grade material

Personalisation area



Industrial bottle trucks

Ideal for collecting, transporting and storing

50mm all swivel nylon castors



**660 (L) x 457 (W) x 635 (H) mm**  
**134 Litre Mobile Industrial Bar Bottle Trolley**

Colour: 

<b>Code</b>	<b>Eg10</b>
<b>Dims Int</b>	550 (L) x 350 (W) x 550 (H) mm
<b>Capacity</b>	134 Litres
<b>Weight (kg)</b>	7.0
<b>Material</b>	MDPE
<b>Castors</b>	50mm swivel nylon

**609 (L) x 457 (W) x 736 (H) mm**  
**151 Litre Mobile Industrial Bar Bottle Trolley**

Colour: 

<b>Code</b>	<b>Eg20</b>
<b>Dims Int</b>	500 (L) x 350 (W) x 660 (H) mm
<b>Capacity</b>	151 Litres
<b>Weight (kg)</b>	6.1
<b>Material</b>	MDPE
<b>Castors</b>	50mm swivel nylon



**965 (L) x 381 (W) x 609 (H) mm**  
**166 Litre Mobile Industrial Bar Bottle Trolley**

Colour: 

<b>Code</b>	<b>Eg50</b>
<b>Dims Int</b>	860 (L) x 265 (W) x 549 (H) mm
<b>Capacity</b>	166 Litres
<b>Weight (kg)</b>	7.0
<b>Material</b>	MDPE
<b>Castors</b>	50mm swivel nylon



**812 (L) x 475 (W) x 609 (H) mm**  
**167 Litre Mobile Industrial Bar Bottle Trolley**

Colour:  

<b>Code</b>	<b>Eg30</b>
<b>Dims Int</b>	700 (L) x 345 (W) x 545 (H) mm
<b>Capacity</b>	167 Litres
<b>Weight (kg)</b>	6.0
<b>Material</b>	MDPE
<b>Castors</b>	50mm swivel nylon



**660 (L) x 609 (W) x 635 (H) mm**  
**167 Litre Mobile Industrial Bar Bottle Trolley**

Colour:  

<b>Code</b>	<b>Eg40</b>
<b>Dims Int</b>	570 (L) x 510 (W) x 560 (H) mm
<b>Capacity</b>	187 Litres
<b>Weight (kg)</b>	6.0
<b>Material</b>	MDPE
<b>Castors</b>	50mm swivel nylon





Mailbox Products ingredients trolleys are popular in commercial and plant bakeries, food manufacturing and processing, hotel and restaurant kitchens and the general hospitality trade. They are ideal for storing, transporting and dispensing dry food ingredients such as flour, cereal, rice, sugar and grain and come in a variety of colours to assist with colour-coding and product separation requirements

- Food approved
- Easy-to-clean mobile storage
- Versatile
- Large, food-approved containers
- Hygienic large ingredients bin
- Personalisation options available



# Mobile Ingredients Bins

65 - 142 litre bins

Ingredients bins are designed to allow easy filling and dispensing but also have lids to protect contents and prevent spills, smells and cross-contamination. They are compact and mobile, so can be stored easily under tables to maximise space utilisation.

- Made from food-grade materials
- Easy to clean
- Robust and durable

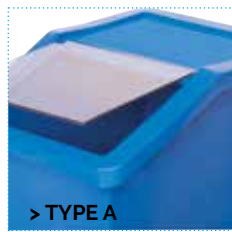

A: Clear PET flap



B: Opaque PP flap



C: Stainless steel flap



610 (L) x 370 (W) x 660 (H) mm  
65 Litre Mobile Ingredients Bin



<b>Code</b>	<b>R204</b>
<b>Dims Int</b>	510 (L) x 270 (W) x 570 (H) mm
<b>Capacity</b>	65 Litres
<b>Weight (kg)</b>	6.8
<b>Material</b>	MDPE



610 (L) x 470 (W) x 660 (H) mm  
89 Litre Mobile Ingredients Bin



<b>Code</b>	<b>R205</b>
<b>Dims Int</b>	510 (L) x 370 (W) x 570 (H) mm
<b>Capacity</b>	89 Litres
<b>Weight (kg)</b>	7.5
<b>Material</b>	MDPE



610 (L) x 570 (W) x 660 (H) mm  
145 Litre Mobile Ingredients Bin



<b>Code</b>	<b>R206</b>
<b>Dims Int</b>	510 (L) x 470 (W) x 570 (H) mm
<b>Capacity</b>	142 Litres
<b>Weight (kg)</b>	8.7
<b>Material</b>	MDPE



# Tabletop Ingredients Bins

24 - 65 litre bins

Ingredients dispensers are ideal for storing and transporting dry ingredients and have an opaque flap lid. They are designed to fit on standard height tables so space is used efficiently.

They are popular in commercial and plant bakeries, food manufacturing and processing, hotel and restaurant kitchens and the general hospitality trade.

- Clear PET Flap
- Made from food-grade materials
- Easy to clean
- Robust and durable
- Adjustable baffle in MDPE for flow control

**Front aperture:**  
R1108 178 x 138mm  
R1109 245 x 193mm

465 (L) x 205 (W) x 460 (H) mm 65 Litre Bin  
Ingredients Bin Complete With Clear Flap Lid



<b>Code</b>	<b>R1108</b>
<b>Capacity</b>	24 Litres
<b>Weight (kg)</b>	2.7
<b>Material</b>	MDPE



610 (L) x 275 (W) x 670 (H) mm 65 Litre Bin  
Ingredients Bin Complete With Clear Flap Lid



<b>Code</b>	<b>R1109</b>
<b>Capacity</b>	65 Litres
<b>Weight (kg)</b>	5.6
<b>Material</b>	MDPE





## Scoops, Scrapers and Jugs UK manufactured

Mailbox Products scoops and jugs are extremely useful items in any environment where product needs to be weighed, measured or moved. Manufactured using a solid one-piece construction, they are designed to provide strength, comfort and usability whilst avoiding germ traps, making them the ultimate in hygiene control.

- Selection of colours
- Made from food-grade materials
- Easy to clean
- Robust and durable
- Metal detectable and anti-bacterial options



107 (Blade L) x 77 (Blade W) x 207 (Overall L) mm  
500g Hygienic Mini Hand Scoop

General Purpose P39

Anti-Bacterial P39AB

Metal Detectable P39MD

Dims Blade 107 (L) x 77 (W) x 207 (OL) mm

Weight (gms) 50

Temp Range -30 +80 (°C)

Material PP



150 (Blade L) x 110 (Blade W) x 250 (Overall L) mm  
1000g Hygienic Small Hand Scoop

General Purpose P40

Anti-Bacterial P40AB

Metal Detectable P40MD

Dims Blade 150 (L) x 110 (W) x 250 (OL) mm

Weight (gms) 100

Temp Range -30 +80 (°C)

Material PP



138 (Blade L) x 187 (Blade W) x 310 (Overall L) mm  
1500g Hygienic Medium Hand Scoop

General Purpose P41

Anti-Bacterial P41AB

Metal Detectable P41MD

Dims Blade 138 (L) x 187 (W) x 310 (OL) mm

Weight (gms) 180

Temp Range -30 +80 (°C)

Material PP

230 (Blade L) x 167 (Blade W) x 355 (Overall L) mm  
2000g Hygienic Large Hand Scoop

General Purpose P42

Anti-Bacterial P42AB

Metal Detectable P42MD

Dims Blade 230 (L) x 167 (W) x 355 (OL) mm

Weight (gms) 300

Temp Range -30 +80 (°C)





175 (L) x 150 (W) x 190 (H) mm  
2 Litre Hygienic Fodder Scoop For Colour Coded Systems

General Purpose P43

Anti-Bacterial P43AB

Metal Detectable P43MD

Dims Int 175 (L) x 150 (W) x 190 (H) mm

Capacity 2 Litres

Weight (kg) 0.23

Temp Range -30 +80 (°C)

Material PP



150 (L) x 175 (W) x 240 (H) mm  
2 Litre Hygienic Pouring Jug For Colour Coded Systems

General Purpose P48

Anti-Bacterial P48AB

Metal Detectable P48MD

Dims Int 150 (L) x 175 (W) x 240 (H) mm

Capacity 2 Litres

Weight (kg) 0.25

Temp Range -30 +80 (°C)

Material PP



220 (Bowl W) x 360 (Bowl L) x 80 (Bowl D) mm  
2 Litre Round Bowl Scoops For Colour Coded Systems

General Purpose P44

Anti-Bacterial P44AB

Metal Detectable P44MD

Dims Bowl 220 (W) x 360 (L) x 80 (H) mm

Capacity 2 Litres

Weight (kg) 0.29

Temp Range -30 +80 (°C)

Material PP



3" (75mm) Small Hand  
Detectable Hygienic Scraper

General Purpose P11

Anti-Bacterial P11AB

Metal Detectable P11MD

Dims Blade 75 (L) x 18-75 (W) x 205 (OL) mm

Weight (kg) 0.4

Temp Range -30 +80 (°C)

Material PP



4" (100mm) Large Hand  
Detectable Hygienic Scraper

General Purpose P12

Anti-Bacterial P12AB

Metal Detectable P12MD

Dims Blade 100 (L) x 18-100 (W) x 250 (OL) mm

Weight (kg) 0.8

Temp Range -30 +80 (°C)

Material PP



4" (100mm) Large Hand  
High Heat Resistant Scraper

Code P12HH

Dims Blade 100 (L) x 18-100 (W) x 250 (OL) mm

Weight (kg) 0.8

Temp Range -20 +240 (°C)

Material HHRN



39 (Blade L) x 12 (Blade W) x 421 (Overall L) mm  
Easy to clean Universal Stirrer with Hanger Loop

General Purpose P51

Anti-Bacterial P51AB

Metal Detectable P51MD

Dims Blade 39 (L) x 12 (W) x 421 (OL) mm

Weight (kg) 1.2

Temp Range -30 +80 (°C)

Material PP



150 (Blade W) x 97 (Overall L) mm  
Easy to clean Small Flexi-Scraper

General Purpose P13

Anti-Bacterial P13AB

Metal Detectable P13MD

Dims Blade 150 (W) x 97 (OL) mm

Weight (kg) 0.24

Temp Range -30 +80 (°C)

Material PP



230 (Blade W) x 118 (Overall L) mm  
Easy to clean Large Flexi-Scraper

General Purpose P14

Anti-Bacterial P4AB

Metal Detectable P14MD

Dims Blade 230 (W) x 118 (OL) mm

Weight (kg) 0.4

Temp Range -30 +80 (°C)

Material PP

# Shovels and Spades

## Food-approved tools

Long handle or as a shorter hand paddle, these hygienic food shovels are a handy and effective way to move grain, flour and many other products. Our food shovels are one-piece mouldings in food approved polypropylene.

- Made from food-grade materials
- Easy to clean
- Robust and durable
- Very strong construction



**240 (Blade W) x 550 (Overall L) mm**  
Hygienic Food Hand Shovel

Colour: 

<b>Code</b>	<b>M700</b>
<b>Dims Blade</b>	240 (W) x 550 (OL) mm
<b>Weight (kg)</b>	0.6
<b>Material</b>	PP



**240 (Blade W) x 970 (Overall L) mm**  
Hygienic Medium Size Plastic Shovel

Colour: 

<b>Code</b>	<b>M701</b>
<b>Dims Blade</b>	240 (W) x 970 (OL) mm
<b>Weight (kg)</b>	1.0
<b>Material</b>	PP



**322 ( Blade W) x 1022 (L) mm**  
Hygienic Large Size Plastic Shovel

Colour: 

<b>Code</b>	<b>M702</b>
<b>Dims Ext</b>	322 ( Blade W) x 1022 (OL)
<b>Weight (kg)</b>	1.3
<b>Material</b>	PP

# Snow Pushers

## Robust design

Mailbox Products snow pushers are lightweight yet extremely efficient at clearing both snow and ice in all weather conditions.

- Lightweight
- Wooden handle
- Available in a selection of colours



**408 (Blade W) x 1195 (Overall L) mm**  
Snow Pusher

<b>Code</b>	<b>T1001</b>
<b>Dims</b>	408 (W) x 1195 (h) mm
<b>Weight (kg)</b>	0.76
<b>Material</b>	PP

**408 (Blade W) x 1410 (Overall L) mm**  
Snow Pusher

<b>Code</b>	<b>T1002</b>
<b>Dims</b>	408 (W) x 1410 (h) mm
<b>Weight (kg)</b>	1.04
<b>Material</b>	PP



**25kg Brown Rock Salt Bags**

<b>Code</b>	<b>T26B</b>
<b>Weight (kg)</b>	25
<b>Material</b>	Rock Salt

**25kg White Rock Salt Bags**

<b>Code</b>	<b>T26W</b>
<b>Weight (kg)</b>	25
<b>Material</b>	Rock Salt



## Heavy-Duty Grit Bins Strong and durable

These robust and durable bins can be sited anywhere ice and snow may need to be removed quickly, for example at public facilities, residential areas, business premises, schools, petrol stations and airports. Can be fitted with optional hasp and staple to make units lockable. Snow shovels, pushers and salt are also available, for a complete winter weather solution.

- Robust hinges ensure easy opening and closing
- Rain channels keep the contents dry
- Optional hasp and staple
- Personalised grit bins
- Recycled versions available



760 (L) x 460 (W) x 690 (H) mm  
200 Litre Grit Bin & Salt Bin with Lid



<b>Code</b>	<b>R146</b>
<b>Dims Ext</b>	760 (L) x 460 (W) x 690 (H) mm
<b>Capacity</b>	200 Litres
<b>Weight (kg)</b>	12.6
<b>Material</b>	MDPE
<b>Optional</b>	Hasp & Staple



1220 (L) x 660 (W) x 750 (H) mm  
340 Litre Nestable Grit Bin & Salt Bin with Lid



<b>Code</b>	<b>R213</b>
<b>Dims Ext</b>	1220 (L) x 660 (W) x 750 (H) mm
<b>Capacity</b>	340 Litres
<b>Weight (kg)</b>	24.6
<b>Material</b>	MDPE
<b>Optional</b>	Hasp & Staple



1140 (L) x 645 (W) x 1070 (H) mm  
400 Litre Grit Bin & Salt Bin with Lid  
Open Pallet Feet



<b>Code</b>	<b>R1054</b>
<b>Dims Ext</b>	1140 (L) x 645 (W) x 1070 (H) mm
<b>Capacity</b>	400 Litres
<b>Weight (kg)</b>	23.5
<b>Material</b>	MDPE
<b>Optional</b>	Hasp & Staple





## Pallets UK manufactured

These pallets are ideal for food production and pharmaceutical environments where a high standards of cleanliness is paramount. Made from the highest quality materials, they are strong and hygienic, with exceptional load capacity.

- Euro and industrial sizes
- All round smooth surfaces for easy cleaning
- Lipped deck as standard, optional flat deck available
- Personalisation service available

**1200 (L) x 800 (W) x 175 (H) mm**  
**Roto Lipped Euro Pallet - 4 Way Entry - 4 Open**

Colour:

Code	R800AL
Dims Ext	1200 (L) x 800 (W) x 175 (H) mm
Weight (kg)	17
Material	MDPE



**1200 (L) x 1000 (W) x 175 (H) mm**  
**Roto Lipped Pallet - 4 Way Entry - 4 Open**

Colour:

Code	R1000AL
Dims Ext	1200 (L) x 1000 (W) x 175 (H) mm
Weight (kg)	20.0
Material	MDPE

Food-grade material

Robust and durable

Personalisation area



Lipped deck

Strong and hygienic

Colour-coding for segregation





# Go Green

New pallet from recycled material

Not suitable for direct food contact applications

**1200 (L) x 1000 (W) x 157 (H) mm**  
**Lipped Deck - 4 Way Entry - 2 Open 2 Boxed**  
**Sided Pallet Recycled Material Pallet**

<b>Code</b>	C3RL
<b>Dims Ext</b>	1200 (L) x 1000 (W) x 157 (H) mm
<b>Weight (kg)</b>	16.0
<b>Material</b>	Recycled HDPE

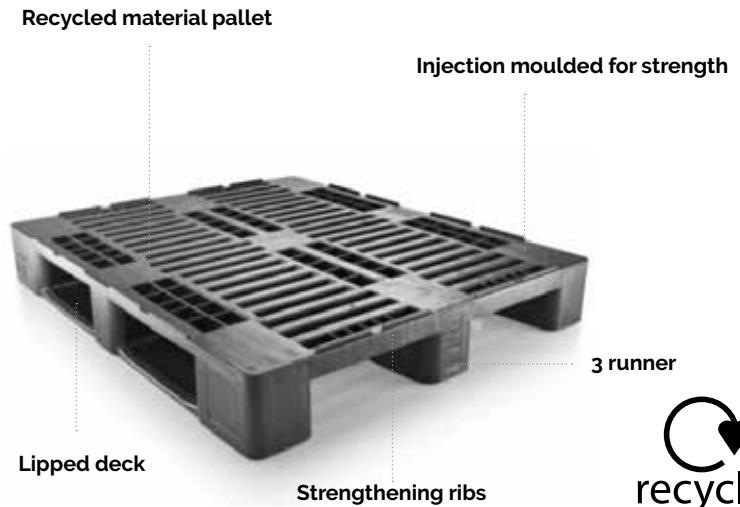

# General Use

Heavy Duty Pallets

Euro pallets are made from high quality materials. They are the universal hygiene pallet and can be used everywhere where cleanliness and hygiene are important.



**1200 (L) x 1000 (W) x 160 (H) mm**  
**Heavy Duty Pallet 4 Way Entry - 2 Open - 2**  
**Boxed with anti-slip lipped and ventilated**  
**deck**

Colour:

<b>Code</b>	C3L
<b>Dims Ext</b>	1200 (L) x 1000 (W) x 160 (H) mm
<b>Weight (kg)</b>	20.0
<b>Material</b>	HDPE

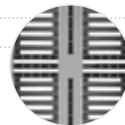

**1200 (L) x 800 (W) x 160 (H) mm**  
**Heavy Duty Euro Pallet 4 Way Entry - 2 Open - 2**  
**Boxed with smooth, lipped deck**

Colour:

<b>Code</b>	C1SL
<b>Dims Ext</b>	1200 (L) x 800 (W) x 160 (H) mm
<b>Weight (kg)</b>	18.0
<b>Material</b>	HDPE

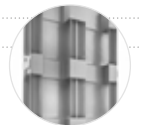

**1200 (L) x 1000 (W) x 160 (H) mm**  
**Heavy Duty Pallet 4 Way Entry - 4 Boxed**  
**with 5 runners and smooth, lipped deck**

Colour:

<b>Code</b>	C3SBL
<b>Dims Ext</b>	1200 (L) x 1000 (W) x 160 (H) mm
<b>Weight (kg)</b>	23.0
<b>Material</b>	HDPE

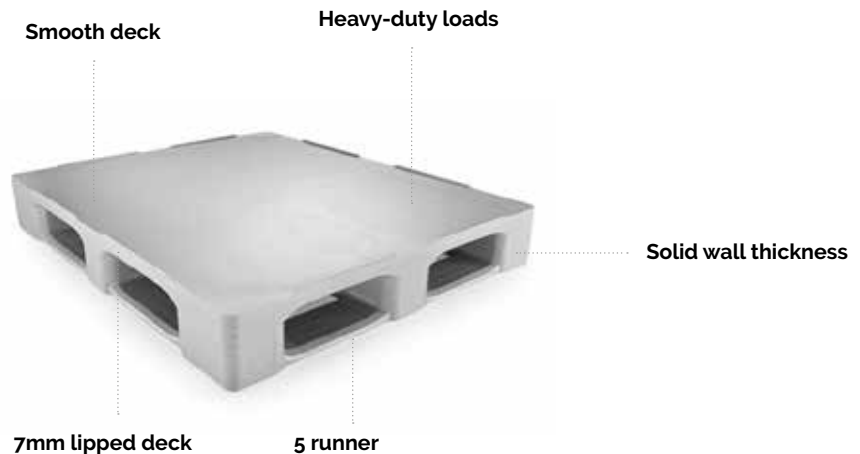
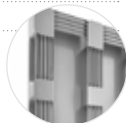

# REA Racking

Euro shelving - 400, 600 deep

Plastic Euro modular storage system, designed with simplicity in mind and the ideal solution to all your product storage needs, especially where hygiene is paramount.

- Made from durable, entirely plastic material
- Rust-proof, resistant to salts and acids from foodstuffs
- Hygienic, easy to clean
- Strong, 200Kgs bearing capacity per metre of shelf
- Resistant to temperatures from -40°C to +80°C

SINGLE BAY

No tools required



Optional mobile units

## 400mm Deep Euro Shelving - Single Bay

Static	Mobile	External			Shelves	Shelf Space
		L	W	H		
S10442035	S10442035M	1000	400	1450	4	350
S10442040	S10442040M	1000	400	1600	4	400
S10442045	S10442045M	1000	400	1750	4	450
S12442035	S12442035M	1200	400	1450	4	350
S12442040	S12442040M	1200	400	1600	4	400
S12442045	S12442045M	1200	400	1750	4	450
S14442035	S14442035M	1400	400	1450	4	350
S14442040	S14442040M	1400	400	1600	4	400
S14442045	S14442045M	1400	400	1750	4	450

## 600mm Deep Euro Shelving - Single Bay

Static	Mobile	External			Shelves	Shelf Space
		L	W	H		
S10642035	S10642035M	1000	600	1450	4	350
S10642040	S10642040M	1000	600	1600	4	400
S10642045	S10642045M	1000	600	1750	4	450
S12642035	S12642035M	1200	600	1450	4	350
S12642040	S12642040M	1200	600	1600	4	400
S12642045	S12642045M	1200	600	1750	4	450
S14642035	S14642035M	1400	600	1450	4	350
S14642040	S14642040M	1400	600	1600	4	400
S14642045	S14642045M	1400	600	1750	4	450

Fast assembly

DOUBLE BAY



H frame

Air circulation



Optional mobile units

Adjustable levers

**400mm Deep Euro Shelving - Double Bay**

Static	Mobile	External			Shelves	Shelf Space
		L	W	H		
S15442035	S15442035M	1500	400	1450	4	350
S15442040	S15442040M	1500	400	1600	4	400
S15442045	S15442045M	1500	400	1750	4	450
S18442035	S18442035M	1800	400	1450	4	350
S18442040	S18442040M	1800	400	1600	4	400
S18442045	S18442045M	1800	400	1750	4	450
S20442035	S20442035M	2000	400	1450	4	350
S20442040	S20442040M	2000	400	1600	4	400
S20442045	S20442045M	2000	400	1750	4	450

**600mm Deep Euro Shelving - Double Bay**

Static	Mobile	External			Shelves	Shelf Space
		L	W	H		
S15642035	S15642035M	1500	600	1450	4	350
S15642040	S15642040M	1500	600	1600	4	400
S15642045	S15642045M	1500	600	1750	4	450
S18642035	S18642035M	1800	600	1450	4	350
S18642040	S18642040M	1800	600	1600	4	400
S18642045	S18642045M	1800	600	1750	4	450
S20642035	S20642035M	2000	600	1450	4	350
S20642040	S20642040M	2000	600	1600	4	400
S20642045	S20642045M	2000	600	1750	4	450

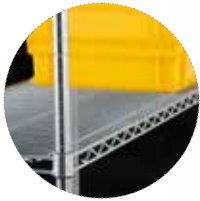

Shelving detail



Optional mobile units

Flat-pack design installation

Strong and stylish

Suitable for dry stores, display, retail and offices

**ACCESSORIES**

- Mobile options available - add "M" to end of part number
- Additional shelves are available as an optional extra

150 kgs load bearing per shelf

## Wire Racking Flat-pack design

Mailbox Products wire racking is an effective shelving system for any commercial or industrial environment. It is elegant, minimalist and timeless. The open wire racking reduces dust accumulation and allows a free circulation of air, greater visibility of stored items and more light penetration.

- Quick assembly
- High gloss finish
- Fully adjustable
- Free circulation of air
- Easy to clean
- Mobile or static use

1590mm High			
Length	355 Deep	460 Deep	610 Deep
915mm	B936	B946	B966
1220mm	B1236	B1246	B1266
1525mm	B1536	B1546	B1566
1825mm	B1836	B1846	B1866

1895mm High			
Length	355 Deep	460 Deep	610 Deep
915mm	B938	B948	B968
1220mm	B1238	B1248	B1268
1525mm	B1538	B1548	B1568
1825mm	B1838	B1848	B1868



# Stainless Steel Wire Racking Flat-pack design

Mailbox Products stainless steel shelving is minimalist and stylish, combining elegance with the strength and flexibility necessary to provide a huge amount of storage with ease. The open design ensures free circulation of air and makes it easy to identify shelf contents. Ideal for healthcare, food service and pharmaceutical applications stainless steel racking can be used with confidence in the most demanding of environments.

- **304 grade stainless steel**
- **Easy to assemble**
- **Visible storage of items**
- **Corrosion-proof**

	1650mm High			
Length	300 Deep	400 Deep	500 Deep	600 Deep
900	B936SS	B946SS	B956SS	B966SS
1200	B1236SS	B1246SS	B1256SS	B1266SS
1500	B1536SS	B1546SS	B1556SS	B1566SS
1800	B1836SS	B1846SS	B1856SS	B1866SS

	1800mm High			
Length	300 Deep	400 Deep	500 Deep	600 Deep
900	B938SS	B948SS	B958SS	B9688SS
1200	B1238SS	B1248SS	B1258SS	B1268SS
1500	B1438SS	B1548SS	B1558SS	B1568SS
1800	B1838SS	B1848SS	B1858SS	B1868SS



4 TIER UNIT

Flat pack design installation

Designed for aggressive applications and cleaning processes

Excellent air circulation

#### ACCESSORIES

- Mobile options available - add "M" to end of part number
- Additional shelves are available as an optional extra

150 kgs load bearing per shelf



# Swift Racking

## Flat pack design

Swift Rack is an ingenious racking system which is easy to assemble. It simply slots together without the use of any nuts and bolts.

Swift Rack is injection moulded in polypropylene around a steel core. It is hygienic, stable, versatile and strong. Load bearing capacity of 150Kgs per shelf, maximum load of 600Kgs per section.

### ACCESSORIES:

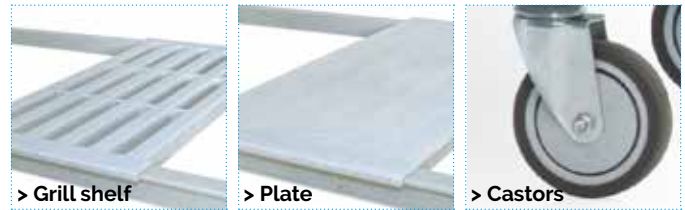

> Grill shelf

> Plate

> Castors

### IDEAL FOR:

- Hotels and food processing preparation areas
- Laboratories - resistant to most chemicals
- Wet areas - Swift Rack is rust-proof
- Cold rooms and freezers to -30°C



Straight bay clip

Easy to clean and dishwasher safe



Freestanding or on castors



Right angle bays support bracket

Adjustable gauges of 100mm

No tools Required

Foot stability

### AVAILABLE IN:

- 2 standard heights, 1500 and 1800mm, with 4 shelves per bay adjustable at gauges of 100mm
- 4 standard lengths, 675, 975, 1375 and 1775mm
- 2 standard shelf depths, 400 and 600mm



150 kgs per shelf

Shelving bay

Hygienic, stable, versatile and strong

Length	1500mm High		Length	1800mm High	
	400 Deep	600 Deep		400 Deep	600 Deep
675mm	A0645	A0665	675mm	A0648	A0668
975mm	A0945	A0965	975mm	A0948	A0968
1375mm	A1345	A1365	1375mm	A1348	A1368
1775mm	A1745	A1765	1775mm	A1748	A1768

### Specify the type of shelf:

- P for plate
- G for grill

### Specify if starter or extension:

- S for starter bay
- E for straight extension
- R for right angle extension

### Specify if units are freestanding or mobile:

- F for freestanding
- M for mobile

Eg:  
A unit which is 1500mm high, has 400mm deep shelves, is 675mm long, has a plate shelf, is a starter bay and freestanding has the reference code of **A0645PSF** Standard bay has 4 shelves. Please specify if extra are required.



A1368PSF Starter unit illustrated with right angle extension bay A1768GRF



**Mailbox**  
www.mailboxproducts.co.uk

Order online: [www.mailboxproducts.co.uk](http://www.mailboxproducts.co.uk) | Call: 0161 330 5577 | Email: [sales@mailboxproducts.co.uk](mailto:sales@mailboxproducts.co.uk)



## Storage lockers High-quality lockers

- Fire tested
- UK-designed and manufactured
- Anti-bacterial powder-coated
- Colour door options

These lockers have also been Fire Tested in accordance with the European Standard EN-13501-01:2007 +A1 2009 for fire performance. This means that they have been tested as non-combustible and will not combust, sustain or increase a fire that is within their proximity. A great choice for use in cloakrooms, corridors and circulation areas within both education and workplaces.

Code	External		H	Doors	Material	Door Colours*
	L	W				
T7729	305	460	1780	1	Mild steel	●●●●●●○
T7730	305	460	1780	2	Mild steel	●●●●●●○
T7731	305	460	1780	3	Mild steel	●●●●●●○
T7732	305	460	1780	4	Mild steel	●●●●●●○
T7733	305	460	1780	5	Mild steel	●●●●●●○
T7734	305	460	1780	6	Mild steel	●●●●●●○
T7736	305	460	1780	8	Mild steel	●●●●●●○
T7737	305	460	1780	16	Mild steel	●●●●●●○

\*All outer cabinets are grey

### Standard lock options at no extra cost



Please request lock type at time of ordering

- A:** Cam lock including 2 keys.  
**B:** Hasp and staple allows easy use of padlock fitting. Shank diameter max 7mm and min 5mm.  
 Padlock not included.

### Premium lock options



\*Additional lock options quoted separately and can be specified at time of ordering

- C:** Radial pin lock offers 10,000 combinations. Supplied with 2 keys.  
**P:** Re-programmable combination lock. 4 digit code with 10,000 combinations. Eliminates use of keys.  
 Master override key sold separately.



- Available with internal power sockets ideal for laptops and mobile phone charging



# Internal Heavy-Duty Litter Bins

Domed and push-top lids

Bright and stylish bins are an excellent way to encourage litter collection and recycling. The slimline design makes these suitable for many environments. The domed hood is available in different colours and there is an optional galvanised steel liner for added versatility.

- High-quality construction
- Strong and durable
- UK-manufactured bins
- Easy-to-clean recycling bins
- Deep rim lid holds and conceals liner bags
- Personalised recycling bins

Perfect for schools and office areas



Personalisation area

358 (D) x 898 (H) mm  
62 Litre Bin with Domed Lid  
Coloured Post Box Bin with Optional Liner



Code	R1164
Dims Ext	358 (D) x 898 (H) mm
Capacity	62 Litres
Weight (kg)	4.7
Material	MDPE



358 (D) x 898 (H) mm  
62 Litre Bin with Push Top Lid Coloured  
Push Top Bin with Optional Liner



Code	R1181
Dims Ext	358 (D) x 898 (H) mm
Capacity	62 Litres
Weight (kg)	4.7
Material	MDPE



## CHOICE OF RECYCLING STICKERS



Bin colour shows through the sticker



Base fitting black or white recycle sticker



# Internal Litter Bins

Encourage recycling and waste collection

Mailbox Products produces a wide range of internal litter bins designed to encourage recycling and waste collection. Whether you need litter bins for offices or busy shopping centres, we have the solution for you. We offer a huge number of different styles and many options for apertures and lids, ideal for any waste collection system.

- High quality construction
- Strong and durable
- UK-manufactured bins
- Easy-to-clean recycling bins
- Nest to save space when not in use
- Personalisation options available



460 (L) x 460 (W) x 880 (H) mm  
100 Litre Bin with Drop-on Coloured Post Box Lid



<b>Code</b>	<b>R1132</b>
<b>Dims Ext</b>	460 (L) x 460 (W) x 880 (H) mm
<b>Capacity</b>	100 Litres
<b>Weight (kg)</b>	6.3
<b>Material</b>	MDPE



460 (L) x 460 (W) x 880 (H) mm  
100 Litre Bin with Drop-on Swing Top Lid



<b>Code</b>	<b>R1133</b>
<b>Dims Ext</b>	460 (L) x 460 (W) x 880 (H) mm
<b>Capacity</b>	100 Litres
<b>Weight (kg)</b>	6.5
<b>Material</b>	MDPE
<b>Flap Colours</b>	



460 (L) x 460 (W) x 685 (H) mm  
100 Litre Bin with coloured Open Top



<b>Code</b>	<b>R1137</b>
<b>Dims Ext</b>	460 (L) x 460 (W) x 685 (H) mm
<b>Capacity</b>	100 Litres
<b>Weight (kg)</b>	5.7
<b>Material</b>	MDPE



460 (L) x 460 (W) x 685 (H) mm  
100 Litre Can & Bottle Recycling Bin  
Two Slot Bin with Recycle Sticker



<b>Code</b>	<b>R1138</b>
<b>Dims Ext</b>	460 (L) x 460 (W) x 685 (H) mm
<b>Capacity</b>	100 Litres
<b>Weight (kg)</b>	5.7
<b>Material</b>	MDPE



460 (L) x 460 (W) x 685 (H) mm  
100 litre Two Slot Paper Recycling Bin  
with Recycle Sticker



<b>Code</b>	<b>R1139</b>
<b>Dims Ext</b>	460 (L) x 460 (W) x 685 (H) mm
<b>Capacity</b>	100 Litres
<b>Weight (kg)</b>	5.7
<b>Material</b>	MDPE

## CHOICE OF RECYCLING STICKERS



Bin colour shows through the sticker



Base fitting black or white recycle sticker





## Wheelie Bins Commercial mobile refuse and recycling bins

Mailbox Products wheelie bins are ideal for heavy-duty industrial or commercial waste collection and storage. They offer a generous capacity but are easy to move thanks to strong wheels. They are available in a range of bright colours for segregation of contents, or in classic dark grey.

- Commercial waste bins
- Personalised wheelie bins
- Strong and durable outdoor bins
- Colour-coded recycling bins



545 (L) x 485 (W) x 825 (H) mm  
90 Litre 2 Wheeled Waste & Recycling Bin



<b>Code</b>	<b>C3508</b>
<b>Dims Int</b>	405 (L) x 395 (W) x 770 (H) mm
<b>Capacity</b>	90 Litres
<b>Weight (kg)</b>	8.4
<b>Material</b>	HDPE



550 (L) x 480 (W) x 960 (H) mm  
120 Litre 2 Wheeled Waste & Recycling Bin



<b>Code</b>	<b>C3509</b>
<b>Dims Int</b>	410 (L) x 395 (W) x 860 (H) mm
<b>Capacity</b>	120 Litres
<b>Weight (kg)</b>	9.6
<b>Material</b>	HDPE



730 (L) x 550 (W) x 1020 (H) mm  
240 Litre 2 Wheeled Waste & Recycling Bin



<b>Code</b>	<b>C3510</b>
<b>Dims Int</b>	565 (L) x 495 (W) x 970 (H) mm
<b>Capacity</b>	240 Litres
<b>Weight (kg)</b>	13.5
<b>Material</b>	HDPE

840 (L) x 650 (W) x 1055 (H) mm  
360 Litre 2 Wheeled Waste & Recycling Bin



<b>Code</b>	<b>U801</b>
<b>Dims Int</b>	675 (L) x 560 (W) x 955 (H) mm
<b>Capacity</b>	360 Litres
<b>Weight (kg)</b>	16.6
<b>Material</b>	HDPE

Durable attached lid



Personalisation area



Large handle

5 colour options

Efficient waste disposal & recycling

Two solid rubber wheels

## 4-Wheeled Bins 660 - 1000 litres

Wheeled bins include a lifting trunnion. This means they can be used in conjunction with REL trucks and compactors with fixed arms as part of a larger materials handling programme or logistics solution. Whatever waste you want to put in them and wherever they are kept, Mailbox Products wheeled bins are more than up to the job.

- Simple hinge mechanism
- 4 swivel castors
- Rear and side vehicle loading
- Colour-coded recycling bins



**1240 (L) x 730 (W) x 1190 (H) mm**  
**660 Litre Wheeled Waste Bin with 4 x 150mm Rubber Swivel Castors, 2 Braked**



<b>Code</b>	<b>U802</b>
<b>Dims Ext</b>	1170 (L) x 660 (W) x 890 (H) mm
<b>Capacity</b>	660 Litres
<b>Weight (kg)</b>	44
<b>Material</b>	HDPE



**1370 (L) x 772 (W) x 1310 (H) mm**  
**750 Litre Wheeled Waste Bin with 4 x 150mm Rubber Swivel Castors, 2 Braked**



<b>Code</b>	<b>U803</b>
<b>Dims Ext</b>	1370 (L) x 772 (W) x 1310 (H) mm
<b>Capacity</b>	750 Litres
<b>Weight (kg)</b>	46.0
<b>Material</b>	HDPE



**1370 (L) x 1070 (W) x 1300 (H) mm**  
**1000 Litre Wheeled Waste Bin with 4 x 200mm Rubber Swivel Castors, 2 Braked**



<b>Code</b>	<b>U804</b>
<b>Dims Int</b>	1040 (L) x 860 (W) x 915 (H) mm
<b>Capacity</b>	1000 Litres
<b>Weight (kg)</b>	54.0
<b>Material</b>	HDPE

Perfect for heavy-duty use



CAT NO	PAGE	CAT NO	PAGE	CAT NO	PAGE	CAT NO	PAGE
A0648	78	B1868SS	77	E8972	62	M208B	20
A0668	78	C1SL	73	E8972	63	M209A	22
A0948	78	C3L	73	H12	31	M211B	27
A0968	78	C3SBL	73	H111	29	M211BH	27
A1348	78	C3508	84	H111SS	29	M211DH	27
A1368	78	C3509	84	H726A	59	M212A	22
A1478	78	C3510	84	H749	50	M213	20
A1768	78	D10	30	H770M	50	M213	21
B936	76	D12	30	H771	50	M213	22
B936SS	77	D1004	31	H1004	31	M213A	20
B938	76	D1208A	54	H1118	29	M213A	21
B938SS	77	D1210A	54	H1118SS	29	M213A	22
B946	76	D8208	54	H1255	45	M214	17
B946SS	77	D8210	54	H1455	46	M214	19
B948	76	E2	55	H200-16	24	M214A	17
B948SS	77	E318	48	H200-8	24	M214A	19
B966	76	E573	47	H201-10	24	M311B	27
B966SS	77	E575B	46	H201-5	24	M311BH	27
B968	76	E577B	46	H3338	49	M311DH	27
B968SS	77	E749	50	H3338SS	49	M700	70
B1236	76	E763	48	H6338	49	M701	70
B1236SS	77	E770	50	H6338SS	49	M702	70
B1238	76	E771	50	K975	56	M712SN	39
B1238SS	77	E817	48	K8975	56	M715	39
B1246	76	E910	64	LINER	81	M716SN	39
B1246SS	77	E920	64	LINER	81	M717SN	39
B1248	76	E930	64	M014B	47	M718	40
B1248SS	77	E940	64	M104A	33	M718R	40
B1266	76	E950	64	M104B	33	M719	40
B1266SS	77	E968	62	M104C	33	M719R	40
B1268	76	E968H	62	M104D	33	M725	37
B1268SS	77	E969	60	M111A	25	M725R	37
B1536	76	E969H	60	M111B	25	M726	59
B1536SS	77	E970	60	M111C	25	M726R	58
B1538	76	E970H	60	M111D	26	M740	36
B1538SS	77	E972	62	M111E	26	M740R	37
B1546	76	E972H	62	M118B	34	M767	36
B1546SS	77	E1104	33	M118C	34	Maximover Range	52
B1548	76	E1104	34	M118D	34	Maximover Range	53
B1548SS	77	E8002	55	M200A	20	O25	42
B1566	76	E8104	33	M200B	20	P1	69
B1566SS	77	E8104	34	M200CH	20	P11AB	69
B1568	76	E8573	47	M201A	21	P12	69
B1568SS	77	E8577	46	M201B	22	P12AD	69
B1836	76	E8763	48	M202A	22	P12HH	69
B1836SS	77	E8817	48	M202D	22	P12MD	69
B1838	76	E8817	48	M203A	16	P13	69
B1838SS	77	E8830	44	M203B	17	P13AB	69
B1846	76	E8830	45	M204A	17	P13MD	69
B1846SS	77	E8968	62	M204B	17	P14	69
B1848	76	E8968	63	M205A	17	P14AB	69
B1848SS	77	E8969	60	M205B	19	P14MD	69
B1866	76	E8969	63	M207A	17	P1MD	69
B1866SS	77	E8970	60	M207B	17	P39	68
B1868	76	E8970	63	M208A	20	P39AB	68

CAT NO	PAGE	CAT NO	PAGE	CAT NO	PAGE	CAT NO	PAGE
P39MD	68	R205B	67	S15442040M	75	U6425	42
P40	68	R205C	67	S15442045	75	U6425R	43
P40AB	68	R206	67	S15442045M	75	U6431	42
P40MD	68	R206A	67	S15642035	75	U6431R	43
P41	68	R206B	67	S15642035M	75	U6436	42
P41AB	68	R206C	65	S15642040	75	U6436R	43
P41MD	68	R213	71	S15642040M	75	U6440	42
P42	68	R800AL	72	S15642045	75	U6440R	43
P42AB	68	R8932	60	S15642045M	75	X300	47
P42MD	68	R8932	63	S18442035	75	X301	47
P43	69	R8967	62	S18442035M	75	X326	48
P43AB	69	R8967	63	S18442040	75	X329	47
P43MD	69	R930	60	S18442040M	75	X332	47
P44	69	R932	60	S18442045	75	X333	47
P44AB	69	R967	62	S18442045M	75	X338	48
P44MD	69	R967H	62	S18642035	75	X345	47
P48	69	S10442035	74	S18642035M	75	X353	44
P48AB	69	S10442035M	74	S18642040	75	X354	45
P48MD	69	S10442040	74	S18642040M	75	X355	45
P51	69	S10442040M	74	S18642045	75	X356	45
P51AB	69	S10442045	74	S18642045M	75	X8338	48
P51MD	69	S10442045M	74	S20442035	75		
R338	55	S10642035	74	S20442035M	75		
R1000AL	72	S10642035M	74	S20442040	75		
R1054	71	S10642040	74	S20442040M	75		
R1072	55	S10642040M	74	S20442045	75		
R1073	55	S10642045	74	S20442045M	75		
R1108	65	S10642045M	74	S20642035	75		
R1109	65	S12442035	74	S20642035M	75		
R1132	83	S12442035M	74	S20642040	75		
R1133	83	S12442040	74	S20642040M	75		
R1137	83	S12442040M	74	S20642045	75		
R1138	83	S12442045	74	S20642045M	75		
R1139	83	S12442045M	74	T26B	70		
R1142	25	S12642035	74	T26W	70		
R1142	26	S12642035M	74	T1001	70		
R1142	27	S12642040	74	T1002	70		
R1142	27	S12642040M	74	T7729	80		
R1164	81	S12642045	74	T7730	80		
R1165	39	S12642045M	74	T7731	80		
R1169	55	S14442035	74	T7732	80		
R1170B	46	S14442035M	74	T7733	80		
R1173	23	S14442040	74	T7734	80		
R1174	37	S14442040M	74	T7735	80		
R1181	81	S14442045	74	T7736	80		
R1208	39	S14442045M	74	T7737	80		
R1210	26	S14642035	74	U801	84		
R1255	45	S14642035M	74	U802	85		
R146	71	S14642040	74	U803	85		
R204	67	S14642040M	74	U804	85		
R204A	67	S14642045	74	U4326	42		
R204B	67	S14642045M	74	U4326R	43		
R204C	67	S15442035	75	U4330	42		
R205	67	S15442035M	75	U4330R	43		
R205A	67	S15442040	75	U6400	42		



## PRODUCTS AND SOLUTIONS

From the UK's leading materials handling specialist

